

Moebius Soft

Manual

Moebius Soft

The screenshot displays three reinforcement design details, each with a table of properties and a small graphical icon.

os	1		
ϕ 6		Layer: 1 	Quant.: x Qt. El: Total= Length 520 Total Len 10.4

os	2		
ϕ 16		Layer: 1 	Quant.: x Qt. El: Total= Length 536 Total Len 21.44

os	3		
ϕ 6		Layer: 1 	Quant.: x Qt. El: Total= Length 131 Total Len

Design of concrete reinforcement.

1. Introduction

- 1.1 Description and consulted codes
- 1.2 Definitions
- 1.3 Parameters of a reinforcing bar schedule
- 1.4 Reinforcing bar schedule in XLS format

2. The reinforcing bar schedule

- 2.1 Summarized sequence to generate a reinforcing bar schedule.
- 2.2 Description of the sheets which make up a reinforcing bar schedule
- 2.3 Edition of a reinforcing bar schedule
- 2.4 Graphic description of the "References" sheet.
- 2.5 Graphic description of the "Job Form" sheet.

3. The structural types





3.1 Slabs

- 3.1.1 General slabs
- 3.1.2 Rectangular slabs
- 3.1.3 Cantilever beam to the to the left
- 3.1.4 Cantilever beam to the right



3.2 Beams

- 3.2.1 End span left
- 3.2.2 Intermediate span
- 3.2.3 End span right
- 3.2.4 Single span
- 3.1.5 Cantilever beam to the left
- 3.1.6 Cantilever beam to the right

3.3 Supports

- 3.3.1 Square columns 
- 3.3.2 Rectangular columns 
- 3.3.3 Rectangular columns 
- 3.3.4 Circular columns 
- 3.3.5 Walls 

3.4 Foundations

- 3.4.1 Square columns on single base 
- 3.4.2 Rectangular columns on single base 
- 3.4.3 Rectangular columns on single base 
- 3.4.4 Single bases

4. The parameters

4.1 General parameters

- 4.1.1 Data for the "Title page" and the "Job Form"
- 4.1.2 Materials
- 4.1.3 Instructions on the "Job Form"
- 4.1.4 Bars anchorage
- 4.1.5 Bars, hooks and stirrup's bending diameters.
- 4.1.6 Slabs
 - 4.1.6.1 Instructions on the "Job Form"
 - 4.1.6.2 Default distances

4.1.7 Beams

- 4.1.7.1 Instructions on the "Job Form"
- 4.1.7.2 Covers, spacing, default diameters and distances

4.1.8 Columns

- 4.1.8.1 Instructions on the "Job Form"
- 4.1.8.2 Minimum dimensions and cover
- 4.1.8.3 Longitudinal (vertical) reinforcing bars.
- 4.1.8.4 Stirrup reinforcement (transversal)

4.1.9 Walls

- 4.1.9.1 Instructions on the "Job Form"
- 4.1.9.2 Minimum dimensions and cover.
- 4.1.9.3 Reinforcing bars
- 4.1.9.4 Vertical reinforcement
- 4.1.9.5 Horizontal reinforcement
- 4.1.9.6 Cross hooks

4.1.10 Columns resting on bases.

- 4.1.10.1 Cover and stirrup spacing
- 4.1.10.2 Longitudinal reinforcement

4.1.11 Single bases

- 4.1.11.1 Covers and maximum spacing between bars.

4.1.12 Default diameters in the selection forms**4.2 Structural elements****4.3 Bar diameters****5. The main menu****5.1 File**

- 5.1.1 New
- 5.1.2 Open ...
- 5.1.3 Save
- 5.1.4 Save as ...
- 5.1.5 Automatic saving...
- 5.1.6 Generate a file in XLS format
- 5.1.7 Page setup
 - 5.1.7.1 Execute the page setup
 - 5.1.7.2 Values for the page setup of this sheet
 - 5.1.7.3 Predefined values for the page setup
- 5.1.8 Preview
- 5.1.9 Print up to the active cell
- 5.1.10 Print ...
- 5.1.11 Screen Resolution ...
 - 5.1.11.1 Define resolution ...
 - 5.1.11.2 Adjust resolution ...
- 5.1.12 Language
- 5.1.13 Description...
- 5.1.14 Exit

5.2 Edit

- 5.2.1 Erase the last scheme
- 5.2.2 Erase a heading and it's schemes
- 5.2.3 Delete a heading and it's schemes
- 5.2.4 Insert rows for a position

- 5.2.5 Delete rows of a position
- 5.2.6 Change the parameters file
- 5.2.7 Edit the parameters ...
- 5.2.8 Edit the list of structural elements ...
- 5.2.9 Edit the diameters ...
- 5.2.10 Adjust the bars cutting length for bending
- 5.3 View**
 - 5.3.1 Normal
 - 5.3.2 Minimize window
 - 5.3.3 Zoom (+)
 - 5.3.4 Zoom (--)
 - 5.3.5 Page breaks
 - 5.3.6 Reinforcement in cm², cm²/m
 - 5.3.7 Anchorage lengths
 - 5.3.8 Control of Dimensions
 - 5.3.9 Calculator
- 5.4 Go**
 - 5.4.1 Go to start
 - 5.4.2 Go to end
 - 5.4.3 Go to position N° ...
- 5.5 Slabs**
 - 5.5.1 General
 - 5.5.2 Rectangular
 - 5.5.3 Cantilever to the left
 - 5.5.4 Cantilever to the right
- 5.6 Beams**
 - 5.6.1 Left end span
 - 5.6.2 Middle end span
 - 5.6.3 Right end span
 - 5.6.4 Single span
 - 5.6.5 Cantilever to the left
 - 5.6.6 Cantilever to the right
- 5.7 Supports**
 - 5.7.1 Square columns
 - 5.7.2 Rectangular columns
 - 5.7.3 Rectangular columns
 - 5.7.4 Circular columns
 - 5.7.5 Walls
- 5.8 Foundations**
 - 5.8.1 Square columns supported on single bases
 - 5.8.2 Rectangular columns supported on single bases
 - 5.8.3 Rectangular columns supported on single bases
 - 5.8.4 Single bases
- 5.9 Help**
 - 5.9.1 Moebius Soft help
 - 5.9.2 Users manual
 - 5.9.3 Enable/Disable special messages
 - 5.9.4 Error report
 - 5.9.5 About Moebius Soft
- 5.10 Undo last action**
- 5.11 Redo last action**
- 5.12 CONTINUE / GO TO THE BAR SCHEDULE**

6. Keyboard

6.1 In a reinforcing bar schedule

6.1.1 In the "Job Form" sheet

6.1.2 In the remaining sheets

6.2 In the scheme selection sheets

6.3 In the parameter, structural elements and diameter sheets

6.4 In the Moebius Soft help sheets

A. Installation and system requirements

1. Installing and uninstalling

2. System requirements

B. Sequence to generate a reinforcing bar schedule using Moebius Soft

1. Edit the parameters, the diameter listing of bars and the items.

2. Change the parameters file

3. Complete Job Form's general heading

4. Execute the menu File \ Page setup \ Execute the page setup and next save the file

5. Choose a structural type and start generating the reinforcing bar schedule

C. Installing the different versions of Excel in the same computer

1. Installing a new version of Excel while keeping the previous one.

2. Installation of a previous version of Excel

3. Start with a previous version of Excel

D. Anchorages and bending diameters per different codes

E. Default values for the page setup

1. Introduction

1.1 Description and consulted codes

Moebius Soft is a program for the scheduling of reinforcing bars and their positioning schemes for different structural types.

Moebius Soft was designed to generate rapidly a job document which makes it possible to place bars within slabs, beams etc., where the bar cutting, bending and placing in the structural element are represented in the same scheme.

Learning of drafting commands is unnecessary, you simply select the different types of reinforcing bar and cross section schemes to generate the reinforcing bar schedule.

Microsoft Excel, Moebius Soft and the Hardlock of Moebius Soft have to be installed in the same computer. The schedule bars and the parameter files can be shared by different users due to the permissions of Read and Write of the files and folders.

Consulted drafting standards: Iso 3766, Din 1356, Sia165, Aci 315-92

1.2 Definitions

The **general heading** is formed by the first lines of the "Job Form" whose edges appear in a double line. It provides the job information, the bar schedule identification, a reference to the general drawing comments, default materials and the date.

Every time you enter **Moebius Soft** or you execute a command : *File \ New*, an empty file appears. The user must complete the general heading of the sheet "Job Form" .

The geometry of the structural elements is shown in the **heading**, in which spans, supports widths or thicknesses are given according to the structural element. In the "Job Form" they are distinguished by a bold line frame.

Following this, the **reinforcing bar schemes** are generated with cross sections or placement schemes depending of the type of structure that's being represented . The user selects the type of scheme and **Moebius Soft** calculates the partial bar lengths based upon the geometry of the element defined in the heading.

The **header** and the **footer** of each of the file pages are references which appear on each file sheet and are introduced automatically or manually when executing a **page setup** using the menu: *File \ Page Setup*

1.3 Parameters of a reinforcing bar schedule

As a file is opened, **Moebius Soft** detects the **parameter file** utilized as the file was saved the last time and suggests utilizing those parameters to maintain the value's consistency.

With the: *Edit \ Change parameter file* menu you may change the parameter file, used for the reinforcing bar schedule. This menu is available only after the bar schedule is opened.

With the *Edit \ Edit the parameters* menu...the user can modify the data that will be utilized in the reinforcing bar schedules for the calculation of bending diameters, spacing etc.

Within the parameter sheet you enable the *Change Parameter File* menu to change the parameter file, *Save Parameter File* to save the values and *Save the Parameter File as ...* to save the parameter file with a different name.

Moebius Soft updates automatically the following sheets: "Title Page", "References", "Quantities", and "Steel Concrete Ratio" with the data generated in the parameter files.

Note: Do not move the parameter files from their default location to avoid having to search for them each time a reinforcing bar schedule is opened.



1.4 Reinforcing bar schedule in XLS format

With: *File \ Generate a file in XLS format* the user generates a file in Excel format.

The user can open, view and print this spreadsheet however, it cannot be modified.

This option enables to deliver a reinforcing bar schedule to an Excel user or to send it by e-mail and keep a duplicate of same.

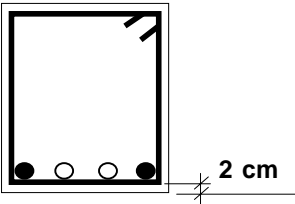
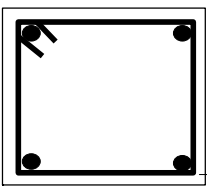
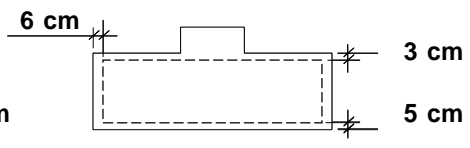
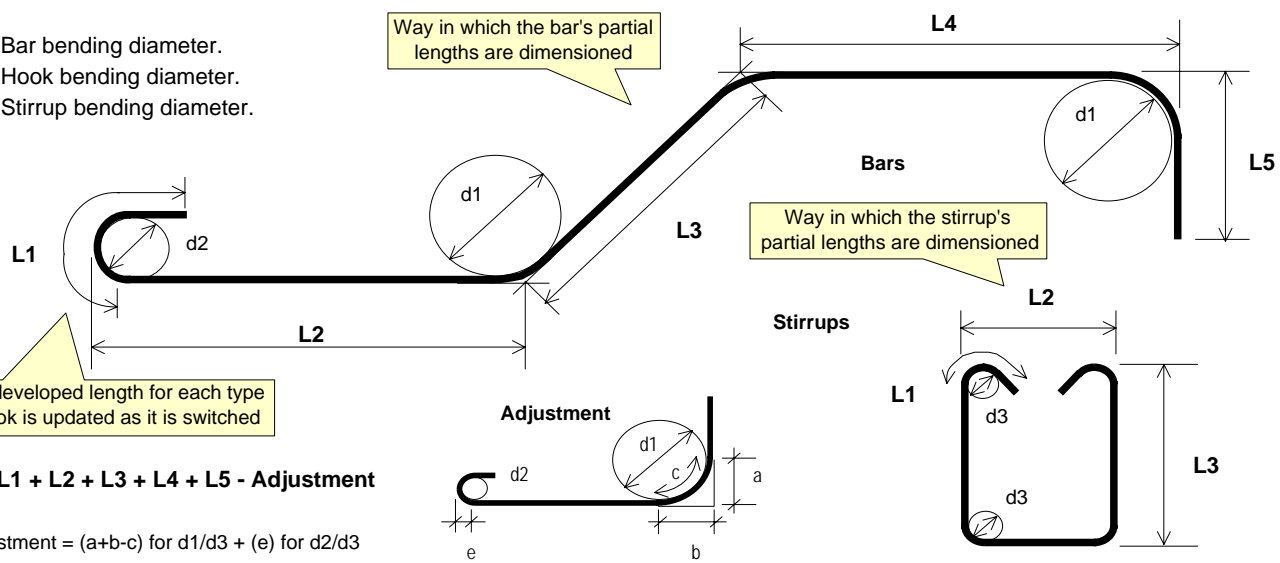
2.4 Graphic description of the "References" sheet.

REFERENCES		
<p>1. Parameters and materials.</p> <p style="text-align: right;">Concrete : H21 Steel : ADN420</p> <p>File: C:\Program Files\Moebius\PAR\DIN1045_H21_A420_Moebius</p>		
<p>2. Covers.</p> <div style="display: flex; justify-content: space-around; align-items: flex-start;"> <div style="text-align: center;"> <p>Beams</p>  <p>2 cm</p> </div> <div style="text-align: center;"> <p>Columns</p>  <p>2.5 cm</p> </div> <div style="text-align: center;"> <p>Bases</p>  <p>6 cm 3 cm 5 cm</p> </div> </div> <p style="font-size: small; margin-top: 10px;"> Belongs to the scheme which appears next to the section. Belongs to other schemes </p>		
<p>3. Lengths and bending diameters</p> <p>d1 : Bar bending diameter. d2 : Hook bending diameter. d3 : Stirrup bending diameter.</p> <div style="display: flex; justify-content: space-between;"> <div style="width: 45%;"> <p style="font-size: small;">The developed length for each type of hook is updated as it is switched</p> <p>L = L1 + L2 + L3 + L4 + L5 - Adjustment</p> <p style="font-size: x-small;">Adjustment = (a+b-c) for d1/d3 + (e) for d2/d3</p> </div> <div style="width: 50%;">  </div> </div>		
<p>3. End hooks</p> <div style="display: flex; justify-content: space-around; align-items: center; margin-top: 20px;"> <div style="text-align: center;">  <p>Drawn hook</p> </div> <div style="text-align: center;">  <p>Hook to be fabricated on site</p> </div> </div>		

2.5 Graphic description of the "Job Form" sheet.

Moebius Soft	General Heading	Studio
Job : Bar schedule : Drawing : Comments :	The Job, Bar schedule, Concrete, Steel and Date will appear in each sheet's headings. After executing the command : <i>File \ Page Setup \ Automatic</i>	Concrete: H21 Steel: ADN420 Date : 20-09-2001

Beam 1	Heading	Dimensions	20 50	N°Fl= 1	ElxFl= 1	N°EL= 1
RefPos 0			50	Dimensions		
Reference Position from which the schemes are numbered				Maximum Stirrup ϕ 6		

Beam 1	Reinf. Bar scheme	20 50	Quant: 4	x	N°El: 1	Total= 4
Pos 1			Length 527 cm			
User's Note ϕ 20 Bar diameter. Anchoring length			Total Length 21.08 m			

Beam 1	Reinf. Bar scheme	20 50	Quant: 34	x	N°El: 1	Total= 34
Pos 2			Length 131 cm			
Bar diameter: ϕ 6 Bar Bending Diameter d3= 2.4			Total length 44.54 m			

Bar Bending Diameter

Reinf.Bar Area Section

3.The structural types

After having selected the structural type, **Moebius Soft** presents a sequence of selection forms which is described for each structural type. The types of forms can be:

- **Heading selection form** : dimensions, the quantity and data of the element are requested.
- **Reinforcing bar selection scheme form** : used to select reinforcing bar types of schemes
- **Section selection form** : used to select among different element sections.
- **Placement scheme selection form** : used to select reinforcing bar placement schemes.
- **Stirrup distribution selection form** : used to choose a stirrup distribution.

Next, the procedures to be followed for each structural type of each form is described.

3.1 Slabs

3.1.1 General slabs

Heading selection form:

1. Select a descriptive scheme of the shape of the slab in plan view.
2. Define the slab dimensions in accordance with the chosen form and the number of elements.
4. Press the **[OK]** button to introduce the heading in the "Job Form".

*Note: The button **[▶]** is enabled after a reinforcing bar scheme has been introduced.*

Moebius Soft suggests the slab N° and the N° of the reference position. The user may change these.

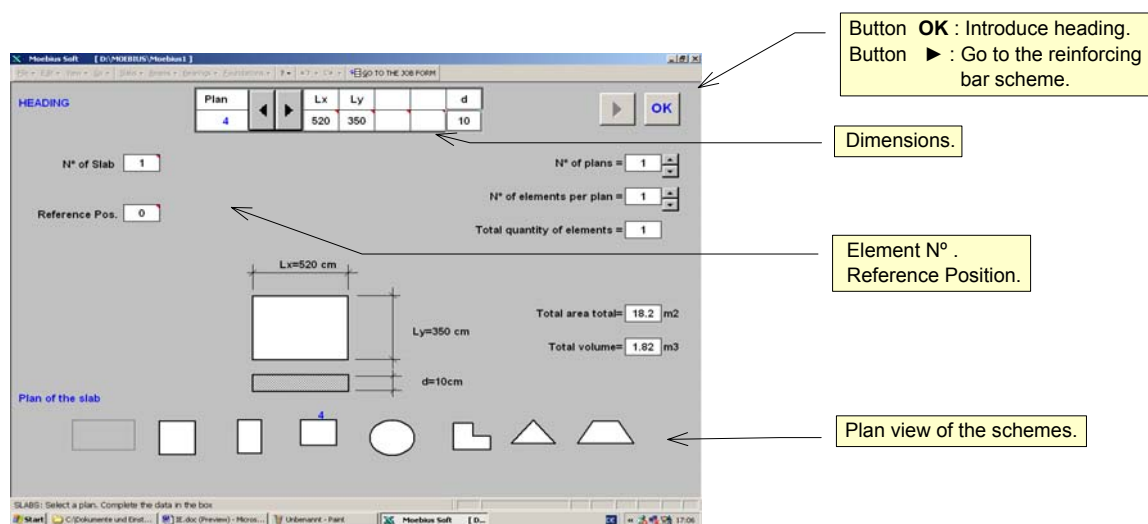

Reinforcing bar scheme selection form :

1. Select a reinforcing bar scheme.
2. Define the partial lengths of the selected scheme, the upper and lower covers, the diameter, quantity and spacing of the bars. Select the type of hooks on the ends.
3. Press the **[OK]** button to introduce the scheme into the "Job Form".

*Note: The button **[▶]** is enabled after a reinforcing bar scheme has been introduced.*

The slab section is introduced automatically with the reinforcing bar scheme.

The plan dimensions don't affect the bar partial lengths.

*You indicate **-a-**, as the width occupied by the bars on the slab as a function of the quantity and spacing of the bars. The covers may be different for each scheme.*

The general slab schemes require a bar placement drawing in plan view.

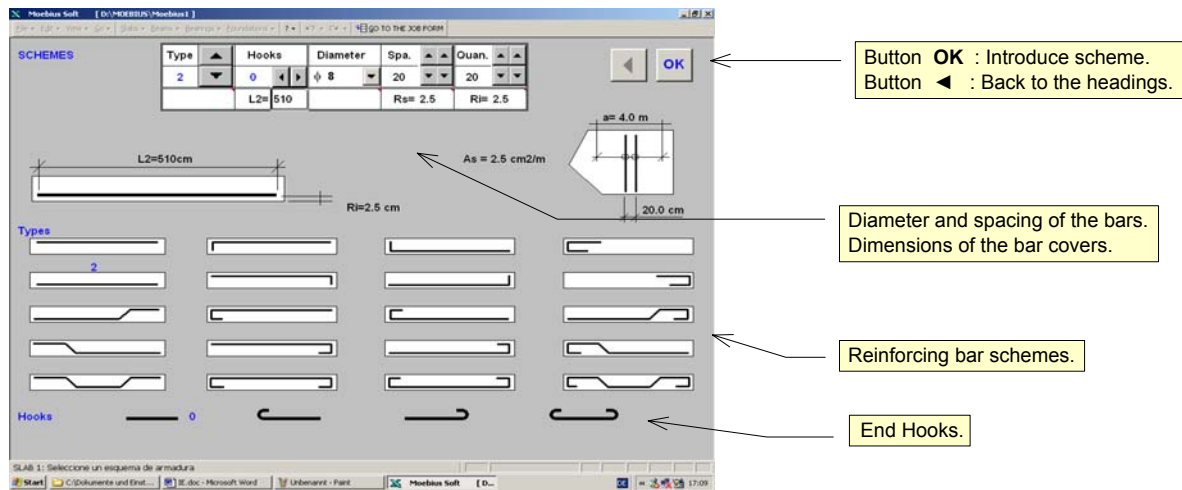

3.1.2 Rectangular slabs

3.1.3 Cantilever beam to the to the left

3.1.4 Cantilever beam to the right

Heading selection form:

1. Select a descriptive scheme for the slab shape in plan view.
2. Define the slab dimensions, the width and name of the bearing and the covers.
3. Define the number of elements.
4. Press the **[OK]** button to introduce the heading into the "Job Form".

*Note: The button **[▶]** is enabled after a reinforcing bar scheme has been introduced.*

Moebius Soft suggests the slab N° and the N° of the reference position. The user may change these.

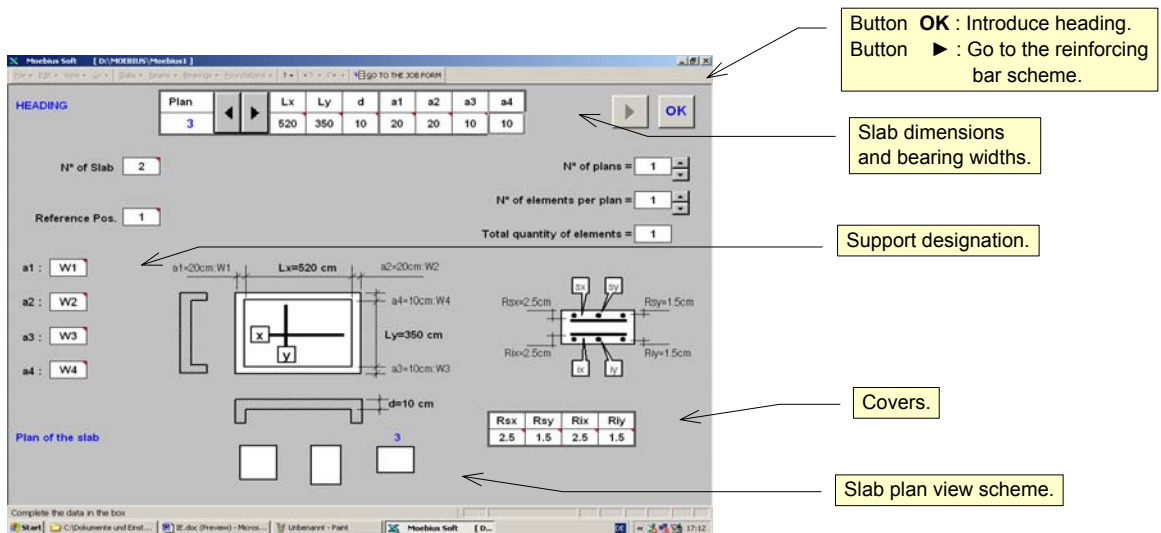

Reinforcing bar scheme selection form :

1. Select a Scheme Type. Define the bar and end hook directions.
2. If option **a = l** is selected, the quantity of bars as a function of the separation and of the slab dimension will be calculated, on the contrary, the user defines the bar quantity and their spacing. Press the **[OK]** button to introduce the scheme in the "Job Form".

Notes: The slab section is introduced automatically with the reinforcing bar scheme.

*You may gain access to another scheme form with the button **[>]**.*

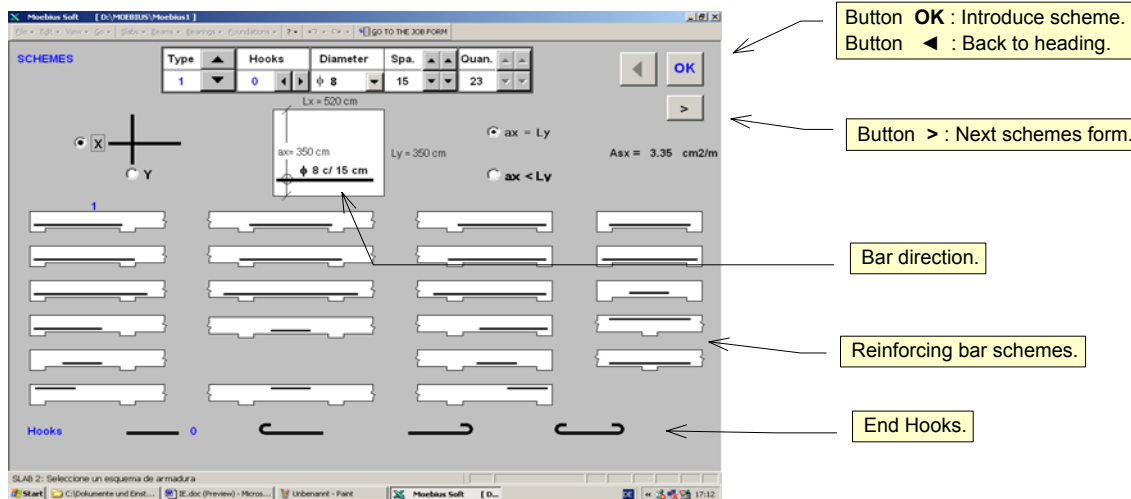

3.2 Beams

3.2.1 End span left

3.2.2 Intermediate span

3.2.3 End span right

3.2.4 Single span

Heading selection form

1. Define beam quantity and dimensions, bearing designation and width.
2. Press **[OK]** button to introduce the heading in the "Job Form".

*Notes **[▶]** button is enabled after having introduced a reinforcing bar scheme.*

Moebius Soft suggests the beam N° and the reference position. The user can change them.

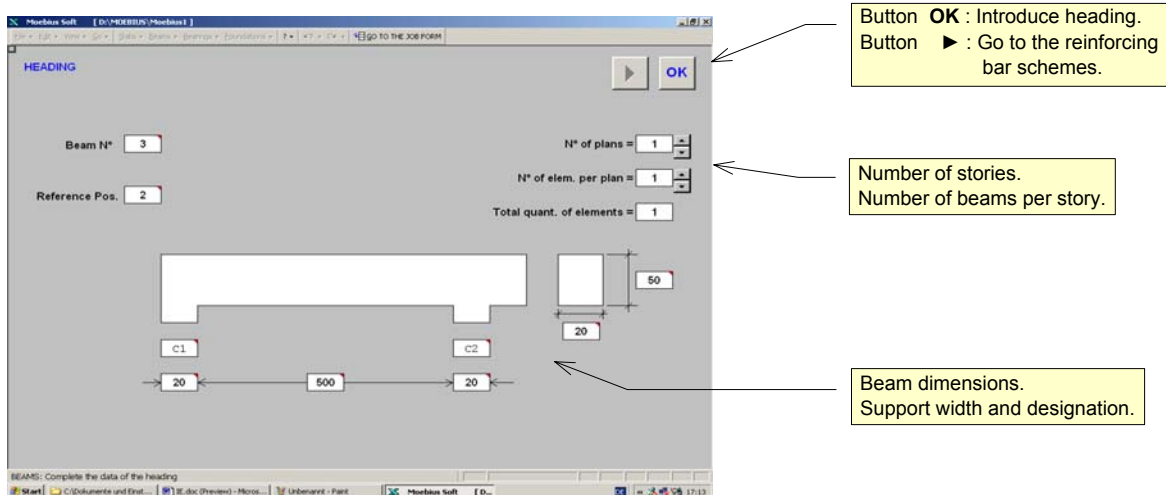

Reinforcing bar schemes selection form.

1. Select a type of scheme and define a type of end hook when applicable.
2. Press the **[OK]** button to go to the sections selection form.

Notes: some schemes and their section are introduced in a single step when the scheme is accepted.

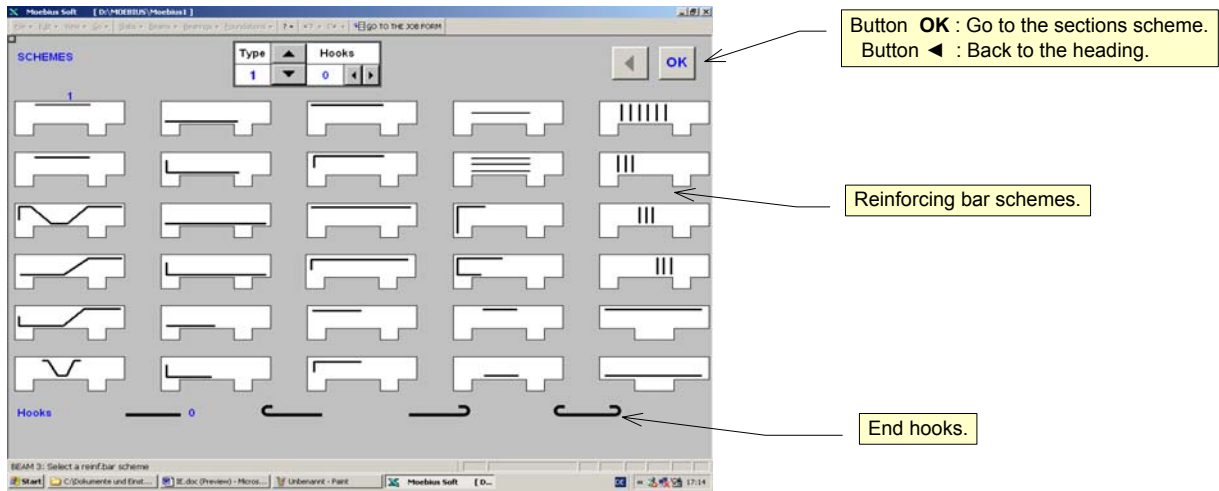

Section selection form :

1. Select a section scheme.
2. Define the $\phi 1$ which corresponds to the selected section and the $\phi 2$ of the bars which complete the reinforcing bar layer, to calculate the total reinforcing bar area and the necessary beam width.
3. Press the **[OK]** button to introduce the reinforcing bar and the section scheme in the "Job Form".

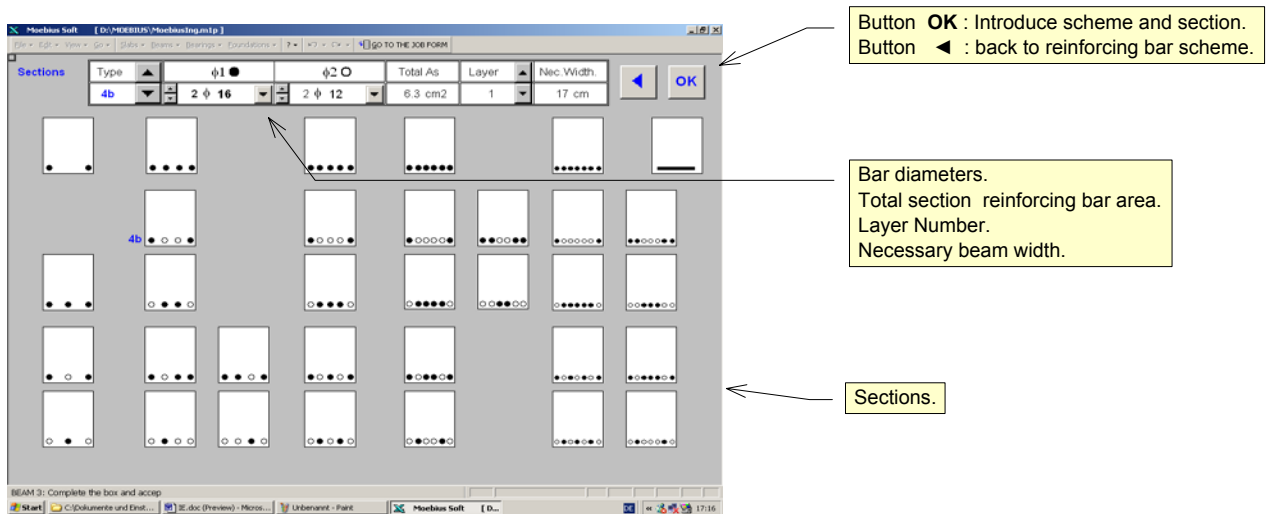

Distance from the beam edge to the bar.

Example : $d = 2\text{cm} + 0.6\text{ cm} + [(2 - 1) \times 4\text{ cm}] = 6.6\text{ cm}$

The formula which was used is the following :

$$d = \text{Cover} + \text{stirrup diameter} + [(\text{Layer } N^\circ - 1) \times \text{distance between layers}]$$

To change the distance manually you may enter a number with a decimal fraction for the layer N° .

The integer of the layer N° will be represented, however, internally the calculation includes the decimal part.

You may change the layer N° (cell with red mark) in the attached scheme and observe the changes.

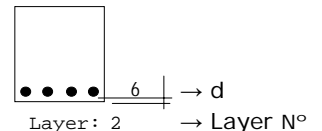

3.1.5 Cantilever beam to the left

3.1.6 Cantilever beam to the right

The selection forms are similar to those of the beams described in the previous sections.

3.3 Supports

3.3.1 Square columns

3.3.2 Rectangular columns

3.3.3 Rectangular columns

Heading selection form:

1. Select one type of floor figure (three types available)
2. Define the quantities, the floor heights, floor description and level (optional)
3. Press the **[OK]** button to go to the section selection form.

Notes: Moebius Soft suggests the column N° and the reference position. The user may change these.

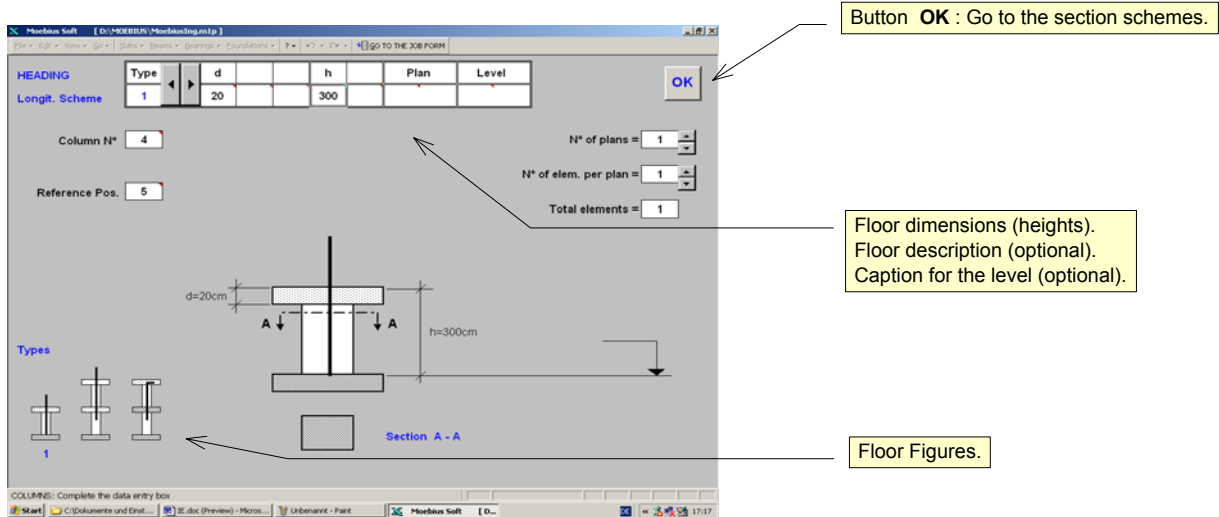

Section selection form:

1. Choose a type of section. With the choice of the section you define the type of stirrup to be used.
2. Define dimensions and diameters. The stirrup diameter is defined according to the parameters.
3. Press the **[OK]** button to introduce the column section and the floor scheme.

Notes: You may gain access to other scheme forms with buttons **[>]** **[<]**

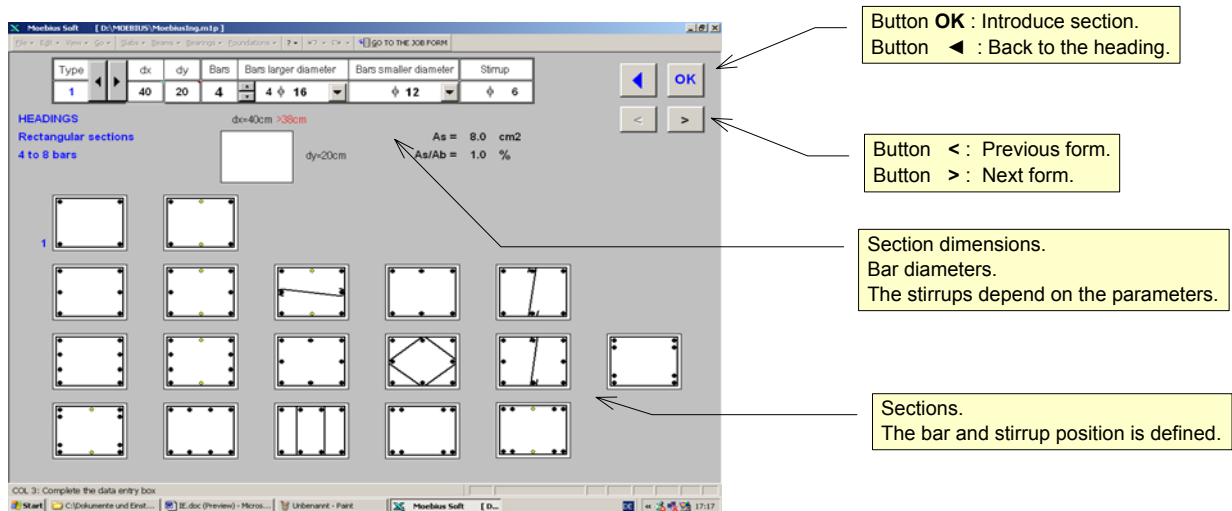

Moebius Soft performs a control of maximum and minimum dimensions based on general parameters. The following formulae are used :

$$dmin. = 2 * cov + 2 * \phi s + N^{\circ}bars * \phi l * (N^{\circ}bars - 1) * emin$$

$$dmax. = 2 * cov + 2 * \phi s + \phi l * N^{\circ}emax * emax + N^{\circ}amax * amax$$

emin : minimum separation between bars

emax : maximum separation between bars' axis without considering buckling

amax : maximum separation between longitudinal grouped bars.

ϕl : Longitudinal bar diameter.

ϕs : Stirrup diameter.

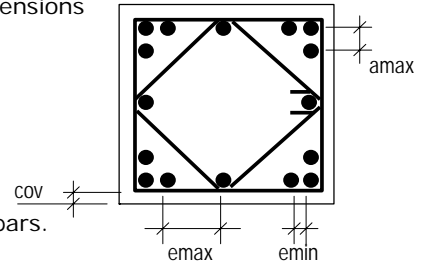

Reinforcing bar scheme selection form:

1. Define the type of reinforcing bar scheme and the quantity.
2. Press **[OK]** button to go to the bar placement selection form.

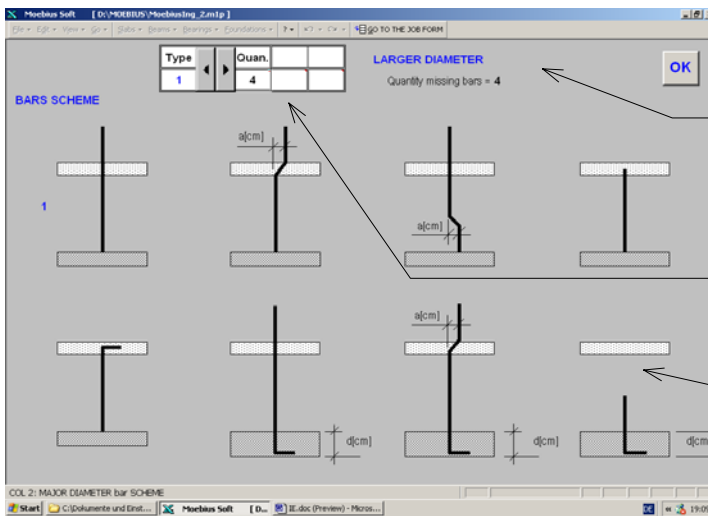

Button **OK** : Go to the bar placement selection form.

Caption which indicates that the scheme of the larger diameter bar is being defined and the quantity yet to be defined.

Bar quantity.

Reinforcing bar schemes.

Placement schemes selection form.

1. Select the bar placement scheme corresponding to the selected reinforcing bar scheme.
2. Press **[OK]** to introduce the reinforcing bar and placement scheme.

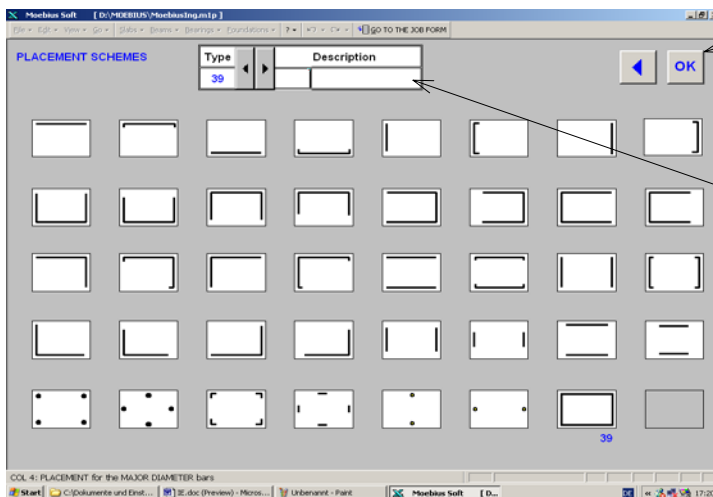

Button **OK** : Introduce the reinforcing bar and placement scheme.
Button **◀** : Back to the reinforcing bar scheme.

Optional description.

3.3.5 Walls

Heading selection form:

1. Select one type of floor figure (three types are available)
2. Define the quantities, the floor height, the floor description and level (optional).
3. Press the **[OK]** button to go to the sections selection form.

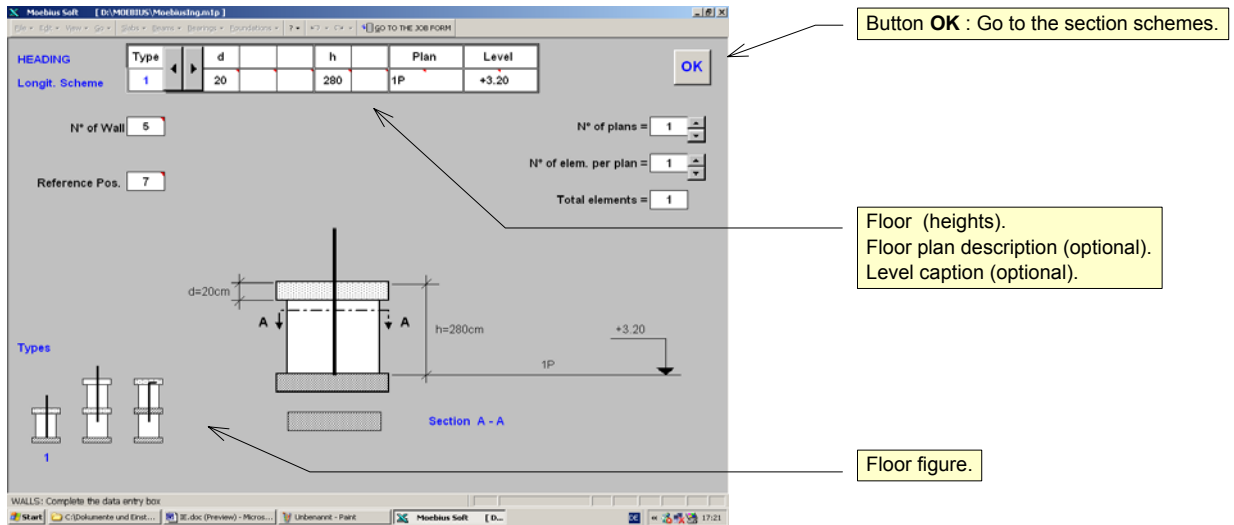

Section selection form:

1. Define the wall dimensions, the reinforcing bars and vertical bars
2. Define if you wish to include cross hooks and of which type
3. Press the **[OK]** button to introduce the wall section and the floor scheme

Notes: We will designate as reinforcing bars the bars which are located at the ends of the wall.

The vertical bars are distributed on both faces of the in a vertical manner and the horizontal bars in a horizontal fashion.

The cross hooks run perpendicularly across the wall and can be selected among three types of hooks.

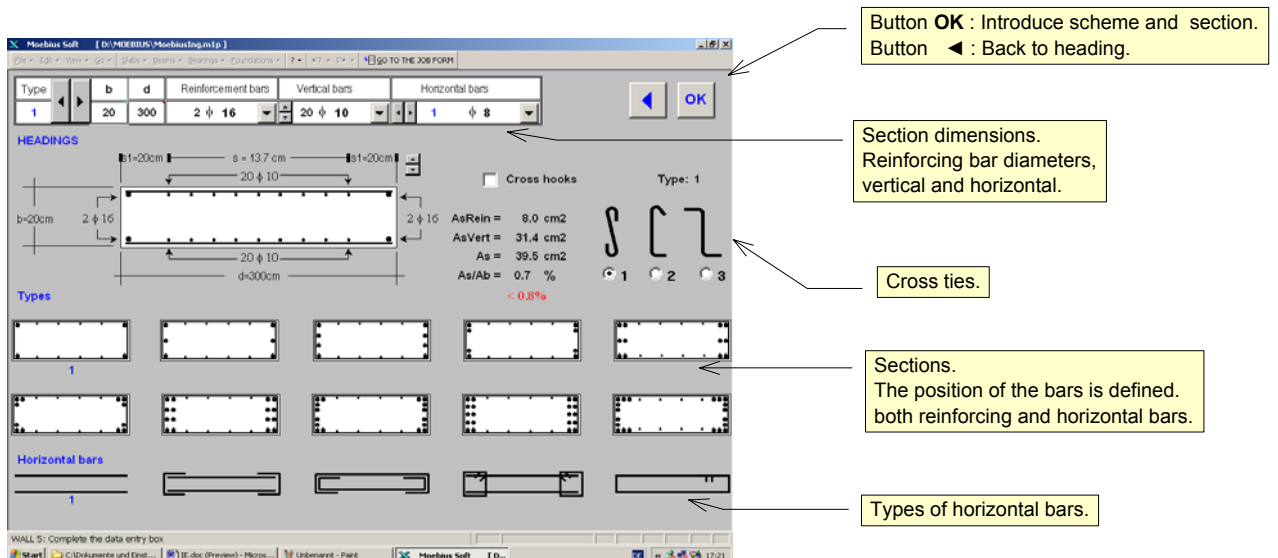

Reinforcing bar scheme selection form.

1. Define the type of reinforcing bar scheme and the quantity.
2. Press **[OK]** to go to the bar placement selection form.

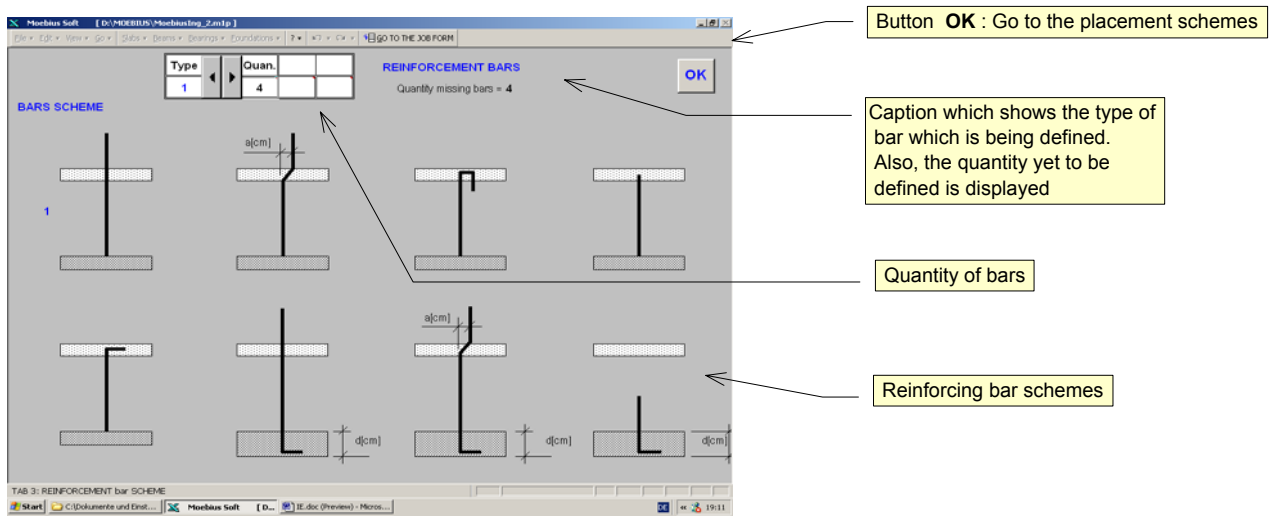

Placement scheme selection form.

1. Select the bar placement scheme which corresponds to the chosen reinforcing bar scheme.
2. Press **[OK]** to introduce the reinforcing bar and the placement schemes.

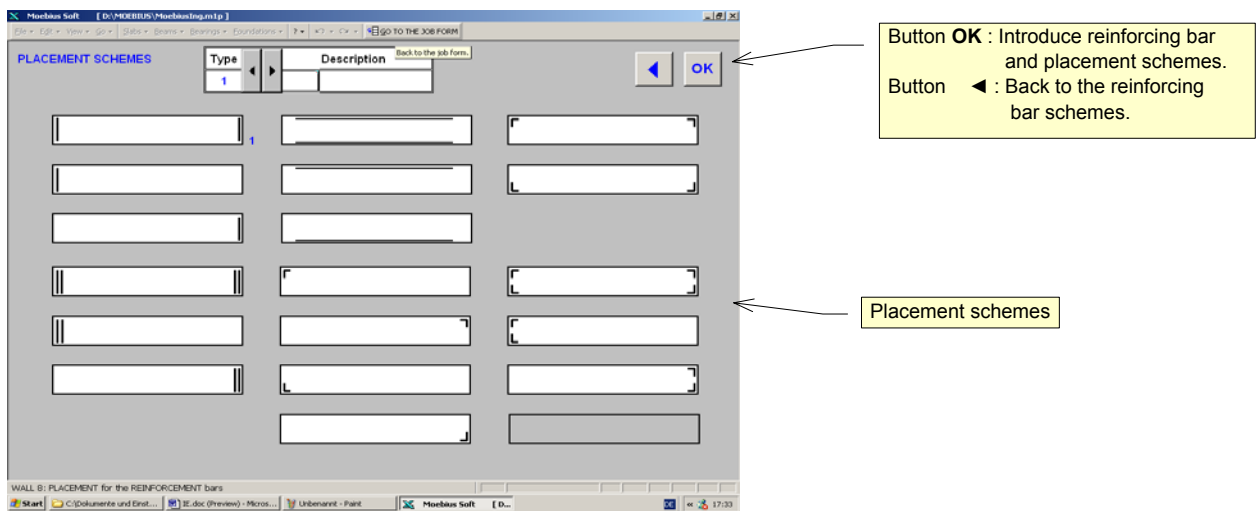

Notes: There is a possibility to change within the "Job Form" the number of vertical bars of the wall in the heading, in which case the bar spacing is recalculated according to the wall's dimensions. The user will have to update the quantities in the vertical bar schemes. Should there not exist a coincidence in the quantities, a message in red characters will appear alerting to this situation.

3.4 Foundations

3.4.1 Square columns on single base

3.4.2 Rectangular columns on single base

The columns with single bases also known as column-trunks, are a variation within the columns which is represented by means of a cross section of the base or footing and the column in a single figure.

Heading selection form:

1. Select one type of footing figure (three types are available).
2. Define the quantities, the footing height and the footing level (optional).
3. Press **[OK]** to go to the section selection form.

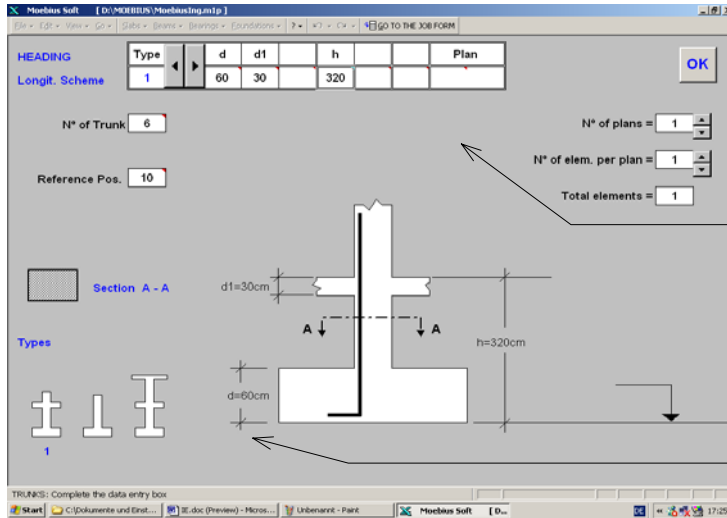

Button **OK** : Go to the section schemes

Footing dimensions (heights).
Caption for the level (optional).

Vertical view to the footing.

Section selection form:

1. Define the type of reinforcing bar scheme and the quantity.
2. Press **[OK]** to introduce the column section and the footing scheme.

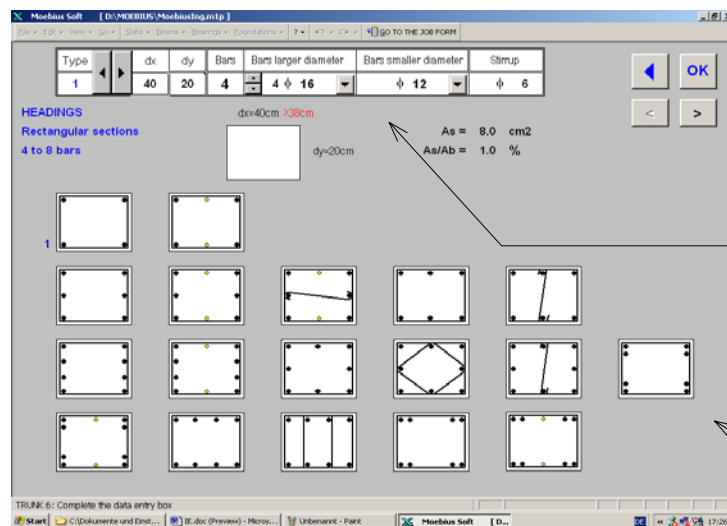

Button **OK** : Introduce scheme and section.
Button **<** : Back to the heading

Button **<** : Previous Form
Button **>** : Next Form

Section dimensions.
Bar dimensions.
The stirrup depends on the parameters.

Sections
Define the position of bars and stirrups

Reinforcing bar schemes selection form:

1. Define the type of reinforcing bar scheme and the quantity.
2. Press [OK] to go to the bar placement selection form.

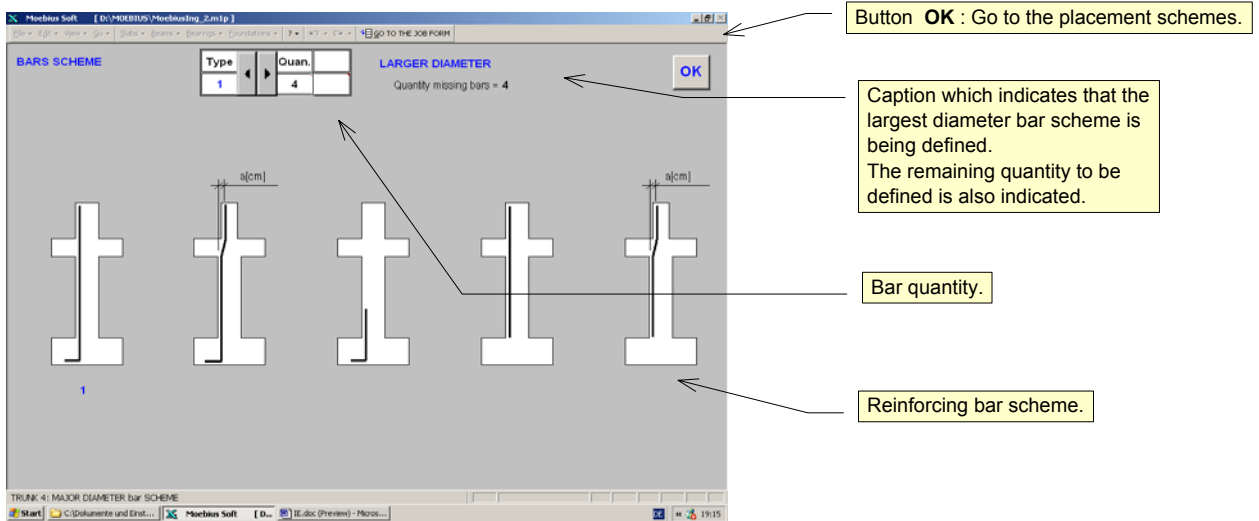

Placement scheme selection form:

1. Select the bar placement scheme corresponding to the chosen reinforcing bar scheme.
2. Press [OK] to introduce the reinforcing bar and the placement schemes.

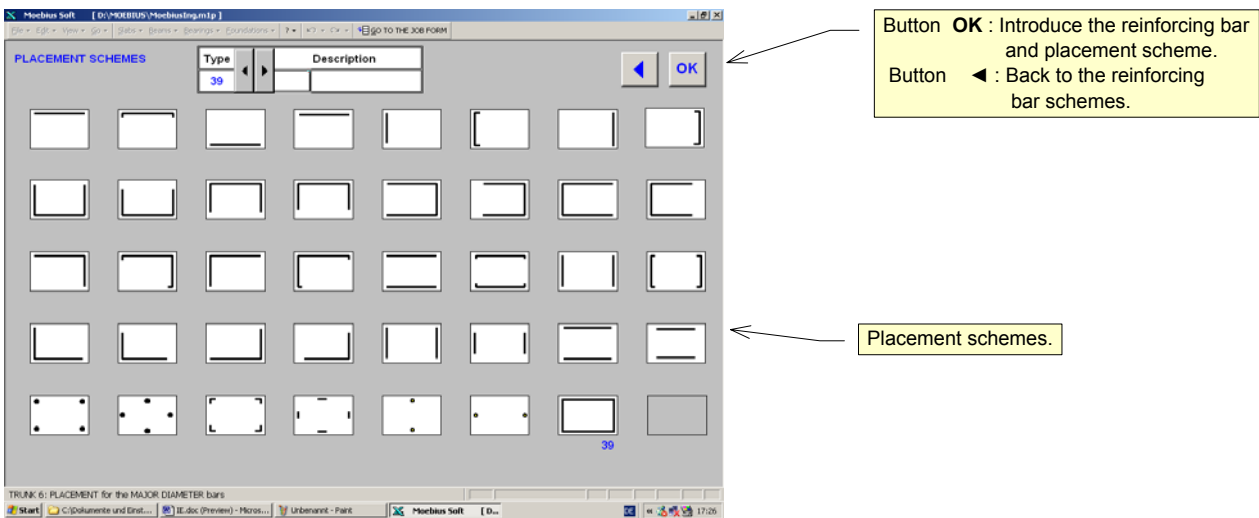

Stirrup distribution selection form:

1. Select the stirrup distribution scheme.
2. Press **[OK]** to introduce the stirrup spacing scheme.

*Notes: In the first two spacing schemes Moebius Soft calculates the values as a function of the footing level and of the reinforcing bar schedule parameters.
In the two remaining, the user enters the requested data.*

The screenshot shows the 'STIRRUPS' selection form in Moebius Soft. At the top, there is a table with the following data:

Type	d	h	Larger diameter	Stirrup
1	60	320	φ 16	φ 6

Below the table, there are four diagrams illustrating different stirrup distribution schemes. The first diagram shows a column with dimensions: 320 cm height, 250 cm width, 5 cm top and bottom clearances, and 15 cm / 17.9 cm spacing. The second diagram shows a column with height h [cm], width d [cm], and various clearances and spacing parameters. The third and fourth diagrams show columns with height h [cm] and width d [cm], with various clearances and spacing parameters.

Callout boxes provide additional information:

- Button **OK** : Introduce the stirrup distribution scheme.
- Stirrup distribution schemes: Automatic spacing calculation.
- Stirrup distribution schemes: Manual data entering.

Notes:

The sequence in which the different selection forms are presented is similar to the one of the columns. What differs from the columns is that there exist three types of stirrup distribution schemes which correspond to the longitudinal schemes which can be chosen from the heading selection form. The stirrup distribution is accomplished according to the dimensions and the parameters.

3.4.4 Single bases

Heading selection form:

1. Select the type of footing.
2. Define the dimensions for the footing and for the column it supports.
3. Press [OK] to introduce the heading in the "Job Form".

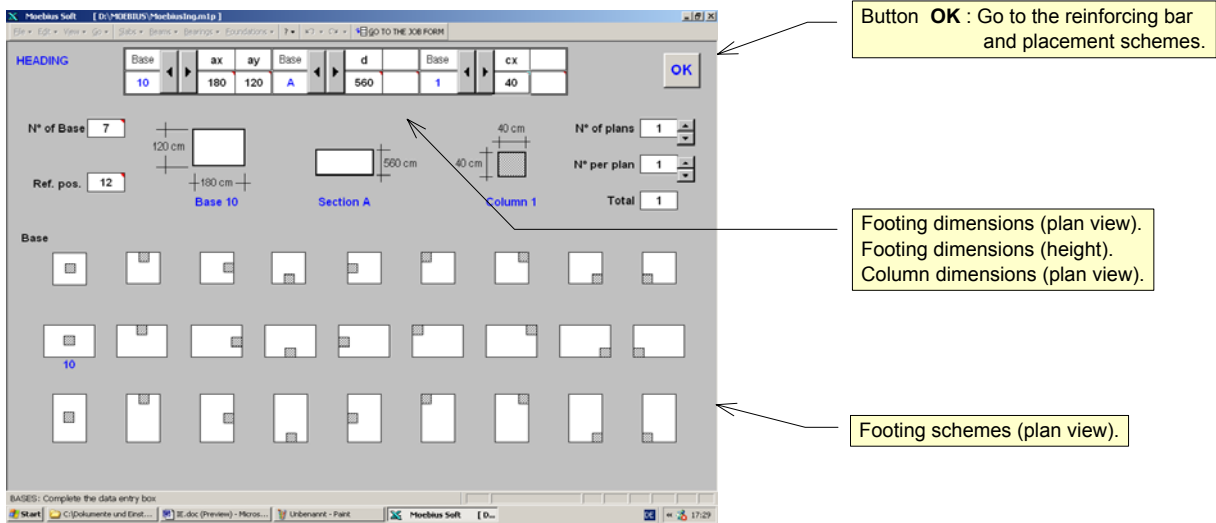

Reinforcing bar selection form and

Placement scheme selection form:

1. Select the type of reinforcing bar scheme and its placement within the footing.
2. Define the number of bars and their placement.
3. Press [OK] to introduce the scheme in the "Job Form".

Notes: Moebius Soft calculates the bar spacing as a function of the footing's dimensions and of the parameters in the reinforcing bar schedule. Upon acceptance both schemes are introduced. The footing dimensions are defined in the heading.

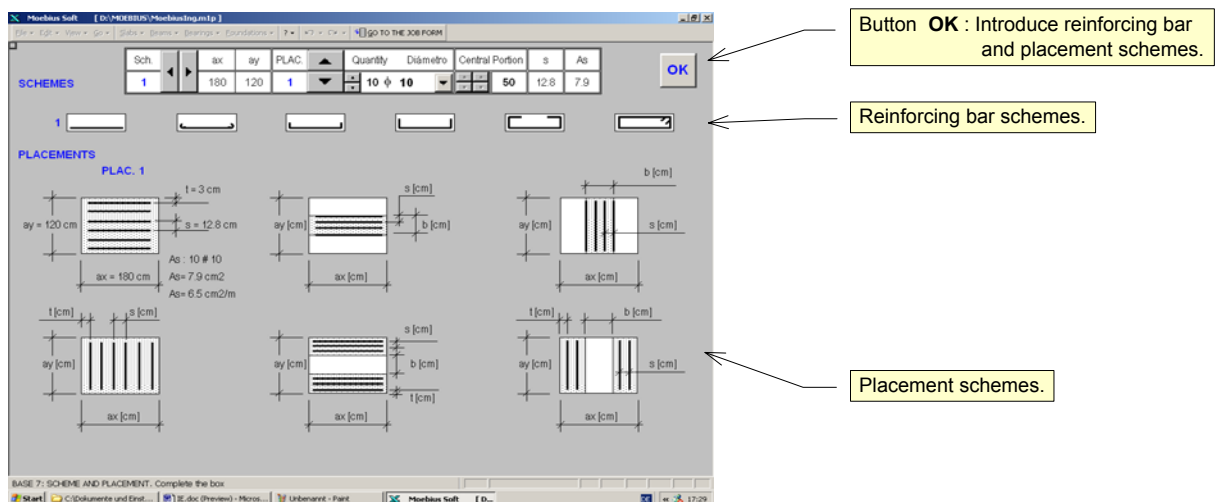

While you are in the "Job Form", if the CONTINUE command is executed, one returns to the same form and the next placement scheme form appears as being proposed (this form is a complement of the previous one). If the Type 1 placement scheme is chosen, the Type 2 will be proposed next and this way the reinforcing bar representation is complete.

If the Type 3 is the chosen one, next Type 4, Type 5 and Type 6 are proposed thereby completing the reinforcing bar representation.

The user may change the proposed sequence should he wish to represent a different reinforcing bar distribution.

- Reinforcing bars in cm², cm²/m
- Visible anchorage lengths.
- Control of visible dimensions.

The structural element control caption, for example: "**Element without calculation**", will appear in the cell the one which designates the structural element when this designation does not correspond underneath to one of those in the list of structural elements.

Strength	Designation	Code: EC2	<input checked="" type="checkbox"/> Reinforcing bars in visible cm ² , cm ² /m
H° = 21	H21		<input type="checkbox"/> Anchorage lengths
A° : 420	A420		<input type="checkbox"/> Control of dimension
Spec. weight of steel	γ : 7.85 dN/m³	Standard length of bars: m	

4.1.4 Bars anchorage

Basic anchorage length: as a function of the bar diameter and varies according to the calculation rule on steel quality and concrete utilized.

Placement factor, favorable or unfavorable: as a function of the placement of the bar within the structural element and it's slant with respect to horizontal reference.

Thickness of the element which defines the zones: According to the calculation rule it is the thickness of the structural element wherein the bar is lodged or the quantity of fresh concrete over the bar in question.

Moebius Soft takes the favorable placement factor for upper or lower bars when the thickness of the element is smaller or equal to the thickness limit. If the thickness is greater for the upper bars it takes the unfavorable placement value.

Minimum anchorage length for the bar ends: Minimum value for anchorage of bars applied to the schemes which have ends at right angles.

Reduction factor of the anchorage length because of and end hook: when the bar has a hook on it's end the anchorage length gets multiplied by this value.

l _o =	44 φ	Basic anchorage length	<input checked="" type="radio"/> Defined by Code	<input type="radio"/> Defined by user
	1	Favorable placement factor.		
	1.3	Unfavorable placement factor		
	30 cm	Thickness of the element which differentiates the zones.		
	0.8	Reinforcement diameter factor. φ ≤ 20 mm		
α =	0.5	Anchorage length reduction factor for end hook.		

4.1.5 Bars, hooks and stirrup's bending diameters.

The bar bending diameter may be obtained as a function of the bar size or reinforcement (ACI criterion) or by the lateral cover, perpendicular to the bending plane (EC2, DIN criterion).

If the reinforcement size is chosen, **Moebius Soft** will adopt as bending diameter the smallest value, if the bar diameter is smaller or equal to the limit diameter φ₁.

For the lateral cover criterion, the user must define two values:

One value which is applied to slabs where the lateral cover and the bar spacing are large and another value which is applied to the remaining elements where the lateral cover and the spacing between bars are lower.

As regards the bending diameter of hooks, the user determines the limit diameter φ₂.

If the hook diameter is smaller than the limit value, the smaller value should be adopted, should the opposite occur, the larger value should be adopted.

For the bending diameter of stirrups, the explanation in the previous paragraph is applicable, except for the limit diameter, which is φ₃. The ACI code differentiates between hooks and stirrups; this is not the case with EC2 and DIN norms which do not make a difference between both elements. In this case the

values for ϕ_2, ϕ_3 , the maximum and minimum are the same.
 The user may choose between three types of end hooks: 180°, 135° and 90° bends.
 The user also defines the straight extension of the hook after bending; this value is a function of the bar diameter. With these data, **Moebius Soft** calculates the length of the developed projection measured from the start of the bend to the far end. [See: 2.4 Graphic description of the sheet References]
 When the user changes the type of end hook the length of the developed projection calculated for every end existing within the "Job Form", is updated. Also the reinforcing bar schedule "References" sheet, the shape of: 'hook to be fabricated on site' is updated, so the user has a graphic reference of the hook to be made.

By reinforcement size By lateral cover

Adjusted cutting length

d1 = **6 ϕ** $\phi \leq 25$ mm d1 = **15** Slabs
 8 ϕ $\phi > 25$ mm d1 = **20 ϕ** Other elements

$\phi_1 =$ **25 mm**

$\alpha =$ **180°**

Hooks

d2 = **4 ϕ** $\phi < 25$ mm
 8 ϕ $\phi \geq 25$ mm
 $\phi_2 =$ **25 mm**

Stirrups

d3 = **4 ϕ** $\phi < 16$ mm
 6 ϕ $\phi \geq 16$ mm
 $\phi_3 =$ **16 mm**

If the command: *Edit \ Adjust cutting length for bending*, is activated the cutting lengths of the bars will be adjusted according to the scheme shown in the "References" sheet.
 The bar cutting lengths will be the sum of the partial lengths, less the adjustment for bends.
 There will also appear a cross in the box next to the caption: 'Adjusted cutting length' in the parameters sheet indicating that the adjustment is activated.

4.1.6 Slabs

4.1.6.1 Instructions on the "Job Form"

The user defines with three check boxes (small square with check mark in it) if he wishes to show:

1. The instruction ax/ay which gives the width in meters covered by the bars in the slab.
2. The designation of the supports defined by the user in the heading of the rectangular slabs.
3. The caption Dir next to the character **x / y** which gives the direction of the bar.

The user must define a ratio between the spans of the slab Lx Ly in such a manner that the slab dimension control will indicate if that ratio has been exceeded. For example: If a slab has been defined as being square in the heading, and if the ratio between the larger and the smaller side exceeds the value indicated by the user in the parameters, a message will appear in red characters, alerting to this situation. This message will appear in the selection forms to prevent introducing in the heading or in the "Job Form" dimensions whose ratio does not match the one defined by the user.

- Indicate ax ay Indicate the supports names
- Indicate caption Direction Difference when controlling the ratio between Lx Ly= **20%**

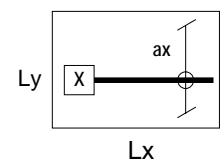

4.1.6.2 Default distances

The distances can be given as a function of the slab dimensions shown in the plan, of the bar diameter in a reinforcing bar scheme or they could be a fixed value. The user can modify the suggested values.

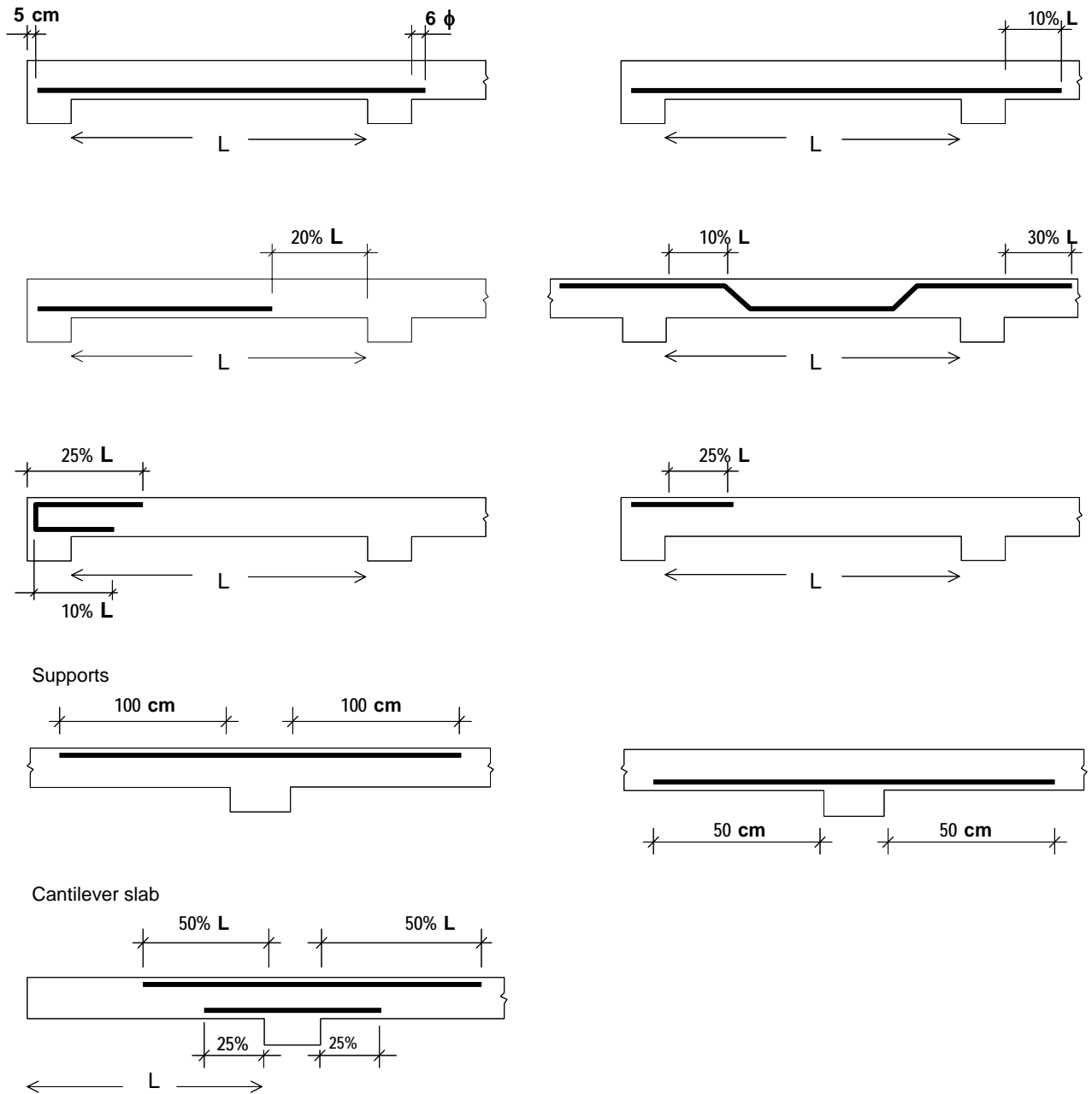

4.1.7 Beams

4.1.7.1 Instructions on the "Job Form"

The user defines with three check boxes (small square with check mark in it) if he wishes to show:

1. The angle β of the bent bars with respect to horizontal.
2. The designation of the supports defined by the user in the beam's headings.
3. An indication of the lack of coincidence between the stirrup's diameters and the maximum diameter shown in the heading. The maximum diameters shown in the beam headings are used to calculate

the bar cover. This cover is calculated as the sum of the stirrup cover, plus the maximum stirrup diameter as shown in the heading.

- Indicate the angle of the slanted bars
- Indicate the name of the supports

- Indicate the lack of coincidence between the stirrup's diameter and the maximum stirrup diameter in the headings.

4.1.7.2 Covers, spacing, default diameters and distances

The user can specify:

1. The stirrup cover.
2. The minimum distance between bars and the spacing between reinforcing bar layers.
3. The default diameter specification is made for the assembly bars located in the upper layer of the beam and for the diameter of the horizontal bars located in the center of the beam.
4. The stirrup anchorage is specified in the case it's closing occurs in a tensioned zone measured from the ending of the stirrup's bend to its end.

The splicing length for stirrup closing in tensioned zones can also be specified.

5. The distances can be as a function of the beam dimensions, of the bar diameters, of a reinforcing bar scheme or it can be a fixed value and their meaning can be defined with schemes.

There is the possibility to specify an angle β by default, for the bent bars.

The user can modify the suggested values in the displayed schemes.

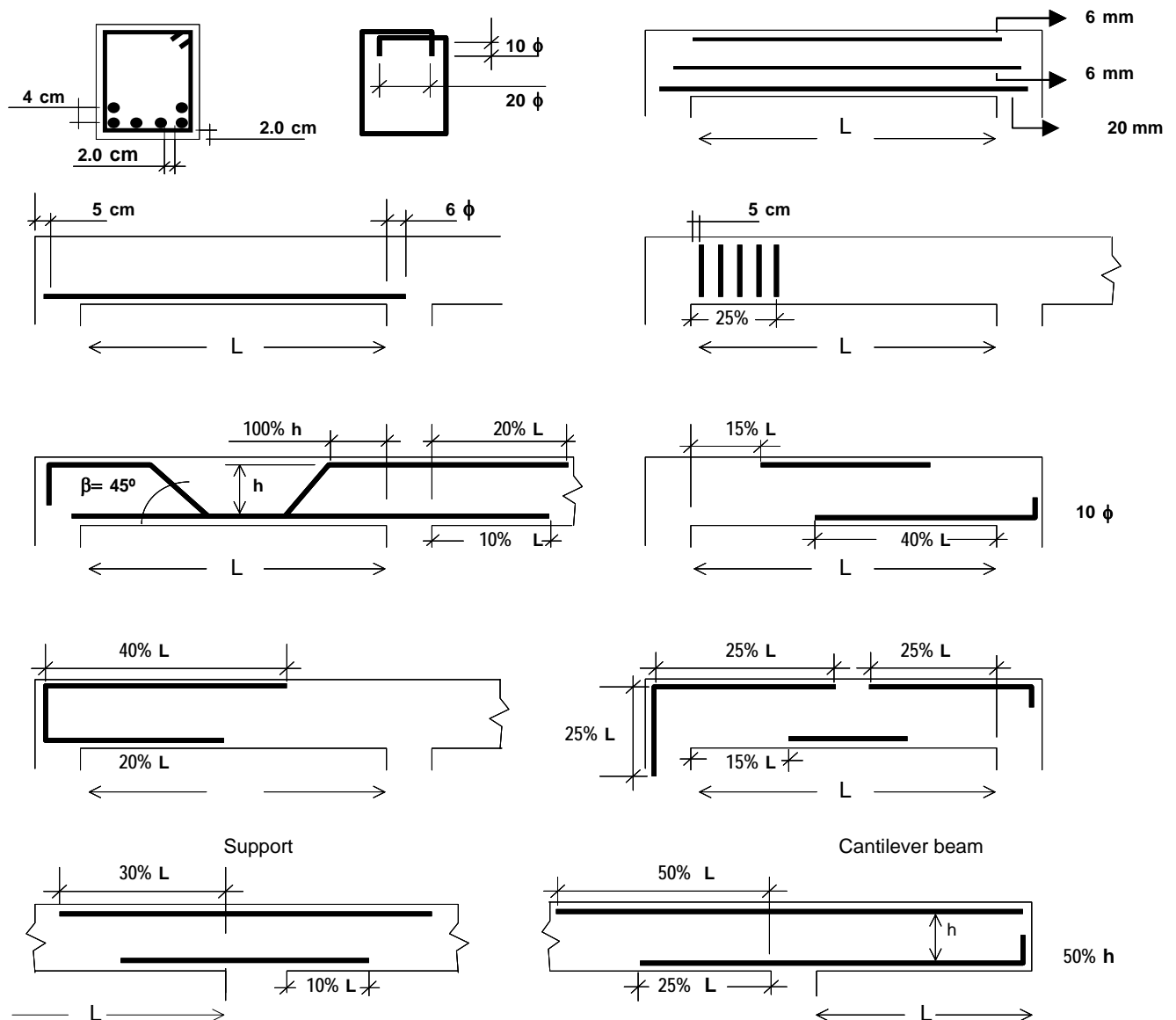

4.1.8 Columns

4.1.8.1 Instructions on the "Job Form"

The user defines with two check boxes if he wishes the following:

1. Appearance of the caption which describes the floor plan where the column is found in all the schemes.
2. Enable the length control of splices in bars which are placed in a staggered pattern.

Enable floor caption

Enable splice length control on staggered bars

4.1.8.2 Minimum dimensions and cover

The user can specify:

1. The minimum side of a column.
2. The cover for the column stirrups.
3. The splice of the type 3 stirrups in a round column.

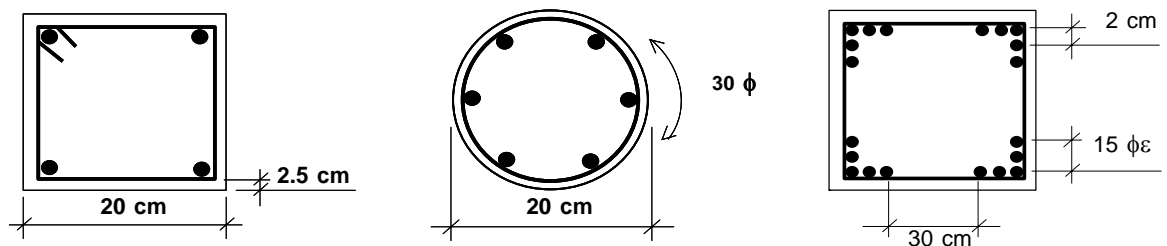

4.1.8.3 Longitudinal (vertical) reinforcing bars.

The user can specify:

1. The minimum spacing of non secured bars against buckling.
2. The minimum spacing of bars of vertical bars in a column.
For control of the minimum dimension of the column, this value should be used for staggered splices, in the case of non staggered splices this value should be doubled.
3. The maximum distance of the bar which is farthest from the corner bar as a function of the column stirrup.
4. The minimum percentage of the area of 'As' steel with respect to the total section 'Ab'
5. The maximum percentage of the area of 'As' steel with respect to the total section 'Ab'
6. The default diameter of the assembly bars (bars used in an auxiliary manner to facilitate the column assembly and for the main bars not to remain unsecured against buckling).
7. The distance of the end of a bar to the upper level of the slab.
8. The slope of the slanted part of a longitudinal bar due to the section change of the column
9. The caption which appears in the column reinforcing bar scheme with staggered splices when the number of bars which come from the lower floor is indicated.

e max. :	30 cm	Maximum distance between longitudinal which are not secured against buckling.
e min. :	2 cm	Minimum distance between longitudinal bars.
a max. :	15 φε	Maximum distance between grouped longitudinal bars.
As/Ab :	0.8 %	Minimum percentage of steel area with respect of the total section area.
	9 %	Maximum percentage of steel area with respect of the total section area (includes splices)
φ :	8 mm	Diameter of the assembly bars/rods.
	1	Factor which multiplies the splice length.

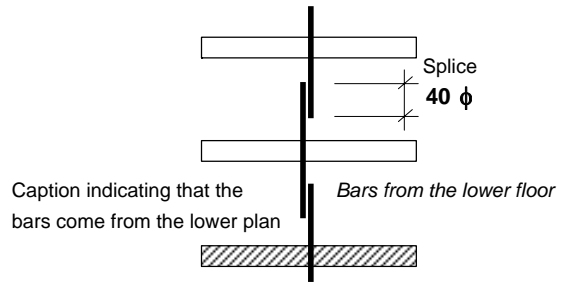
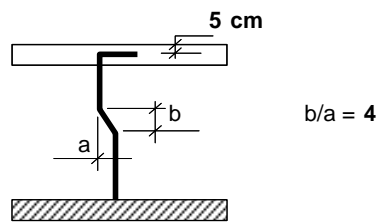

4.1.8.4 Stirrup reinforcement (transversal)

The user can specify:

1. Stirrup's minor diameter.
 2. Stirrup's major diameter.
 3. The limit diameter of the longitudinal bar which requires of the stirrup of major diameter.
 4. The distance between the first upper stirrup and the upper level of the slab.
 5. The number of stirrups to be placed in a reinforcement in the upper part of the column with the purpose of reinforcing it in the case of columns with moments on both ends.
 6. The spacing as a function of the diameter of the longitudinal bar the stirrups should have in the reinforcement zone mentioned in the previous paragraph.
 7. The spacing of stirrups as a function of the major diameter of the longitudinal bars.
- Moebius Soft* rounds off the spacing to the next lower value of this spacing related to the number of stirrups.
8. Spacing of the stirrups in the splicing zone.
 9. The distance between the first stirrup and the upper level of the slab.
 10. Spacing of the secondary stirrups in the case of the columns with more than one stirrup: can be set as simple or double.
 11. Caption to indicate the double stirrup spacing: if the selected option was double spacing the specified caption will appear in the "Job Form" under the stirrup.
 12. Caption which appears next to the number (2) of stirrups which form the reinforcing bar scheme in the case that the stirrup assembly consists of 2 stirrups.
- The user can edit this caption and enter, for example: 4 branches.

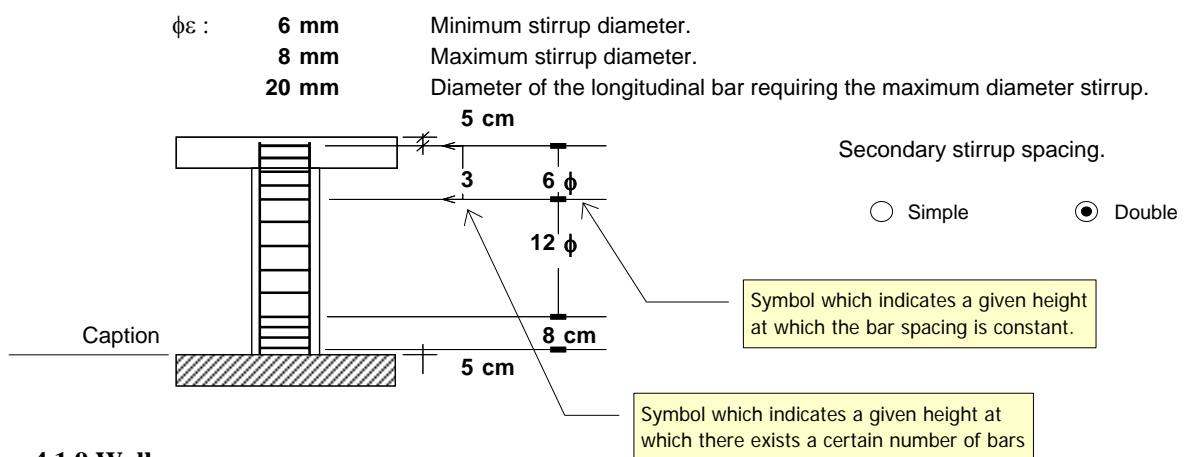

4.1.9 Walls

4.1.9.1 Instructions on the "Job Form"

The user defines with two check boxes if he wishes the following:

1. Appearance of the caption which describes the floor plan where the column is found in all the schemes.
2. Enable the length control of splices in bars which are placed in a staggered pattern.

Enable floor plan caption

Enable splice length control on staggered bars

4.1.9.2 Minimum dimensions and cover.

The user can specify:

1. The minimum side of the wall.
2. The minimum relationship between sides.
3. The horizontal reinforcing bar (external) wall cover.

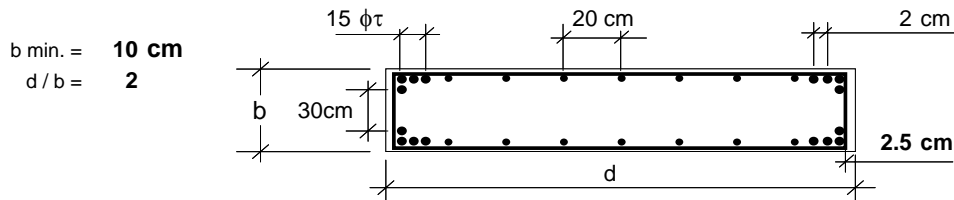

4.1.9.3 Reinforcing bars

These are the reinforcing bars on both ends of the wall. The following is specified:

1. The maximum spacing of the reinforcement bars which are not secured against buckling.
2. The minimum spacing of the wall reinforcement bars.
For the control of the minimum wall dimension, this value will be taken for staggered splicing in the case of non-staggered splicing the double of this value should be taken.
3. The maximum distance of the bar which is farthest from the reinforcement corner bar as a function of the diameter of the wall reinforcement bars.

e max. :	30 cm	Max. distance between long. reinforcement bars which are not secured against buckling.
e mín. :	2 cm	Minimum distance between longitudinal reinforcement bars.
a máx. :	15 φτ	Maximum distance between grouped longitudinal reinforcement bars.

4.1.9.4 Vertical reinforcement

These are the vertical reinforcing bars placed on both sides of the wall. The following is specified:

1. The minimum bar diameter.
2. The maximum bar spacing.
3. The minimum percentage of the area of 'As' steel with respect to the total section 'Ab'.
4. The maximum percentage of the area of 'As' steel with respect to the total section 'Ab'.

Note: The distance from the end of a vertical bar to the slab's upper level and the extension of the vertical bars whose upper end is bent in a U shape are the same as those defined in the columns.

φ L min.:	8 mm	Minimum diameter for the vertical bars.
sL max.:	20 cm	Default spacing for vertical bars.
As/Ab : min.:	0.8 %	Minimum percentage of steel area with respect to the total section area.
max.:	9 %	Maximum percentage of steel area with respect of the total area (including splices).

4.1.9.5 Horizontal reinforcement

These are the horizontal reinforcing bars located on both sides of the wall. The following is specified:

1. The minimum bar diameter.
2. The maximum spacing between bars.
3. The caption that appears under the bar scheme when it consists of more than one element. For example: bars, rods.
4. The distance between the first upper bar to the upper level of the slab.
5. The number of bars which should be placed in the reinforcement zone in the upper part of the wall with the purpose of reinforcing it in the case of walls with moments on both ends.

6. The spacing which the bars should have in the reinforcement zone mentioned in the previous paragraph.
7. The maximum spacing between horizontal bars.
Moebius Soft rounds off the spacing to the next lower value of this spacing related to the number of horizontal bars.
8. Spacing of the bars in the splicing zone.
9. The distance between the first lower bar and the upper level of the slab.

ϕ T min.: **6 mm** Minimum diameter for horizontal bars.
 sT max.: **30 cm** Default spacing for the horizontal bars.

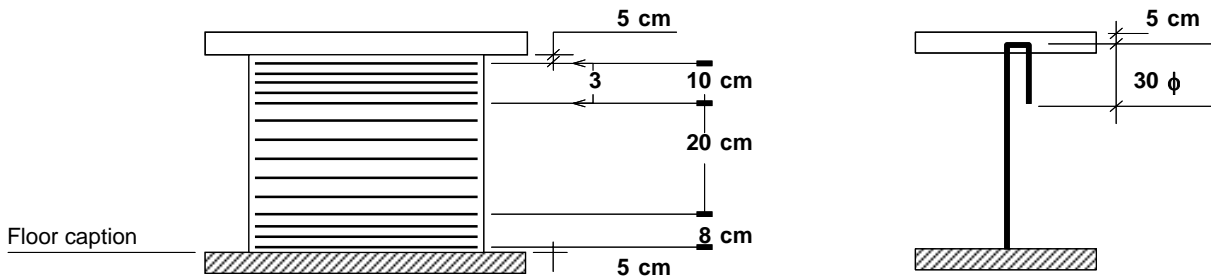

4.1.9.6 Cross hooks

These are reinforcing bars which run across the wall from one side to the other, to secure the vertical and horizontal reinforcing bars. The following is specified:

- 1.The default diameter for transversal hooks.
- 2.The default quantity per m2 of transversal hooks.
3. The caption that appears next to the quantity per sq.mt. of transversal hooks. For example:
'hooks per m2'.
4. The caption which appears in place of the previous one when the user erases the cell that specifies the quantity per m2. and **Moebius Soft** calculates the total number of hooks to be placed in each one of the intersections of the vertical and horizontal reinforcing bars. For example: 1 hook in each intersection.
5. The extension of the type 3 hook.

ϕ : **6 mm** Diameter of the cross hooks.
4 hooks per m2 Quantity of transversal hooks per m2
1 hook in each intersection. Caption of 1 hook in each bar intersection.

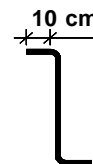

4.1.10 Columns resting on bases.

The specifications of the columns resting on bases are similar to those of columns and the data for these are valid unless otherwise specified in the following paragraphs.

4.1.10.1 Cover and stirrup spacing

The user can specify:

- 1.The cover of the stirrups.
2. The distance between the first upper stirrup to the upper level of the reinforcement beam or upper level of the column whichever applies.
- 3.The distance of the first lower stirrup lodged within the column with respect to the upper level of the base.
4. The distance of the first upper stirrup lodged within the column with respect to the upper level of the base.
5. The distance of the first lower stirrup lodged within the column with respect to the lower level of the base.
6. The spacing between stirrups lodged within the column as a function of the longitudinal bar's major

diameter. **Moebius Soft** rounds off the spacing to the next lower value of this spacing related to the quantity of stirrups.

7. Spacing of the stirrups in the splicing zone in the column.
8. The spacing of the stirrups lodged within the base as a function of the of the bar's major diameter.

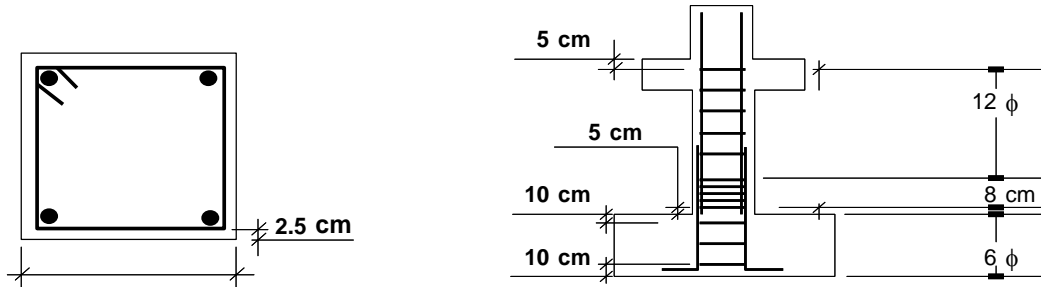

4.1.10.2 Longitudinal reinforcement

The user can specify

1. The caption which appears in the reinforcing bar schemes of the single base columns with staggered splices when the quantity of bars coming from the base is indicated.



4.1.11 Single bases

4.1.11.1 Covers and maximum spacing between bars.

The user can specify:

1. The lower, upper and lateral covers.
2. The maximum spacing between bars.
3. The distance between the column and the beginning of the slanted face of the base which acts as the support for the column's casing.
4. The default anchorage of the bar in it's ends as a function of the bar diameter.

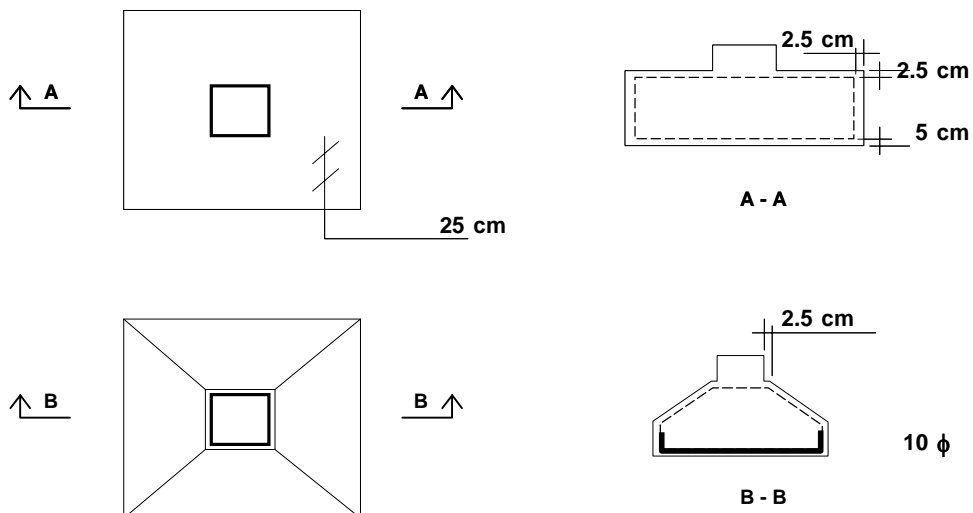

4.1.12 Default diameters in the selection forms

These are the diameters which appear by default in the selection forms within the structural types.

4.2 Structural elements

The structural elements are utilized to calculate the volumes of concrete in cubic meters and the steel/concrete ratios which are Kilograms of Steel per cu.m.(Kg/m³).

Moebius Soft suggests the designation of the 6 structural elements as follows:

- | | | |
|---------|---------|----------|
| 1. Slab | 3. Col | 5. Col-F |
| 2. Beam | 4. Wall | 6. Base |

The names of the first 6 str. elemt. match the designation introduced by Moebius Soft in each heading of the different structural types.

Should the user change one of these 6 structural elements in the item listing he must change the designation of each corresponding heading for the element to be taken into account in the calculations.

Should there be a mismatch in the designation, the caption specified in 4.13 will appear in the "Job Form" under the cell which shows the designation in the heading of each corresponding element.

The user may add another 4 structural elements, but he will have to adhere to what was said previously.

The usefulness of adding another item could be that of differentiating two types of beams showing Beam1 and Beam 2 as structural elements and next editing the heading in the "Job Form" according to the structural elements list. In this manner we will have both the calculations and the steel/concrete ratios differentiated for structural elements Beam1 and Beam2. We could also generate an item Foundation Slab and use General Slabs as structural type to generate the heading and the reinforcing bar schemes of a foundation slab.

4.3 Bar diameters

Moebius Soft has the capacity to define 10 different diameters for reinforcing bars.

The unit of measure of these is (mm.)

Should there be a mismatch in the bar diameter of any scheme, this will appear in the "Job Form" below the cell with the measurement in mm, as a caption in red characters: **Control**

5. The main menu

5.1 File

5.1.1 New

Opens an empty reinforcing bar schedule.

5.1.2 Open ...

To select a reinforcing bar schedule.

5.1.3 Save

Saves a reinforcing bar schedule.

5.1.4 Save as ...

Saves the reinforcing bar schedule with a name. (Name.m1p)

5.1.5 Automatic saving...

Allows establishing how often CONTINUE is operated before **Moebius Soft** saves the bar schedule after confirmation by the user.

5.1.6 Generate a file in XLS format

The user confirms that a reinforcing bar schedule will be generated in XLS format with the following features:

- 1.The reinforcing bar schedule to be generated is an Excel spreadsheet which can be opened viewed or or printed by anyone using Excel.
- 2.The generated spreadsheet cannot be modified by any user. To modify it one must generate it again after making the corrections with **Moebius Soft**.

This is useful to generate a backup copy of a **Moebius Soft** file before modifying the parameters or to deliver it to the person for whom the information is meant.

5.1.7 Page setup

5.1.7.1 Execute the page setup

The page setup performs the following operations:

1. Adjusts the margins, centering, orientation, paper size, and the adjustment as a percentage of the normal page size according to the default values.
2. Places the page breaks according to the default quantity of schemes for each sheet.
3. Transfers information about parameters and the general heading of the reinforcing bar schedules to the headers and footers of each page of the bar schedule and remaining pages ("Title page", etc.) The information on the Studio and the Telephone is transferred from the parameters and placed in the page footer. From the general heading the information on the job designation and the bar schedule designation are transferred and placed in the heading of each bar schedule sheet. The date defined by the user is placed in the footer.

5.1.7.2 Values for the page setup of this sheet

The menu: *Values for the page setup of this sheet* opens the Page Setup dialog box thus allowing manual edition of all the setup values of each sheet.

If the page setup is performed on the "Job Form" sheet, a dialog box is opened to define the quantity of schemes to place per page from among 4, 5, 6 or 7 depending on the paper type which is being used and the percentage adjustment of the normal page size.

5.1.7.3 Predefined values for the page setup

With this menu Moebius Soft's predefined values for each page are restored.

It is always recommended to execute the *File \ Preview* command before printing.

[See annex E](#) for the predefined values

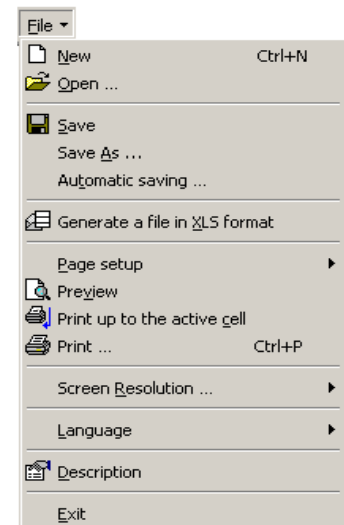

5.1.8 Preview

This command allows viewing the bar schedule before printing.

To view all the sheets, namely: "Title Page" [A], "References" [B], "Quantities" [C], "Steel/Concrete Ratios" [D], "Job Form" [E] simultaneously use the command: *File \ Print* and when the dialog box appears, select the option Print: All the book and next press the button Preview. While being in the mode Preview, the user can enter the Page Break mode to view the Page Breaks and eventually to change them.

To return to the normal view, the command: *View \ Normal* must be executed. This command is active only while being in the Preview mode.

5.1.9 Print up to the active cell

It is used to print the "Job Form" up to the active cell that is, the one over which the cell selector is. When the sheets: "Title Page" [A], "References" [B], "Quantities" [C], "Steel/Concrete Ratios" [D], are selected, this command prints the selected sheet and changes the caption in the corresponding menu.

5.1.10 Print ...

The dialog box Print is opened, with it you can select the printer type and it's properties, print some pages of the "Job Form" or a selection of it, and generate several copies.

To print all of the pages: "Title page" [A], "References" [B], "Quantities" [C], "Steel/Concrete Ratios" [D] and "Job Form" [E] together, use the command: *File \ Print* and when the Print dialog box appears, select the option Print: **All the book**.

5.1.11 Screen Resolution ...

5.1.11.1 Define resolution ...

The user can choose to define the resolution manually. This one must match the one established in the control panel so that the pages adjust themselves correctly. Should there be any problem in the automatic detection, a box will appear which enables the manual resolution selection.

5.1.11.2 Adjust resolution ...

By means of this command, the user can adjust the manner in which the pages adjust themselves in the screen varying the adjustment from (-5 to 5) to view the pages closer or further.

The reinforcing bar schedule sheets or the selection sheets may be adjusted separately.

5.1.12 Language

By means of this command, the user can select the language to be used.

5.1.13 Description...

With this command a box is opened, by means of which you may leave a record of who made and checked the bar schedule with it's dates and write a general comment regarding it as a reminder.

5.1.14 Exit

One may exit *Moebius Soft*. The user is consulted as to whether he wishes to set up the sheets if this option was not accomplished or if one wishes to save the file, if changes have been added to it.

5.2 Edit

5.2.1 Erase the last scheme

With this command the last reinforcing bar scheme corresponding to a given heading is erased.

Previously The user must enable the upper left cell of the scheme.

Which means that should the a beam's description consist of a heading and 4 schemes, the user can erase the last one. If he tries to erase a scheme between the heading and the last heading he will get a message on the impossibility to execute the command.

When *Moebius Soft* finds schemes which where introduced simultaneously in the bar schedule, for example a double column stirrup, when the erase command is executed both schemes will be erased.

5.2.2 Erase a heading and it's schemes

The user can erase a heading and it's scheme in a single step.

Before executing this command the upper left cell of the heading to be erased must be enabled.

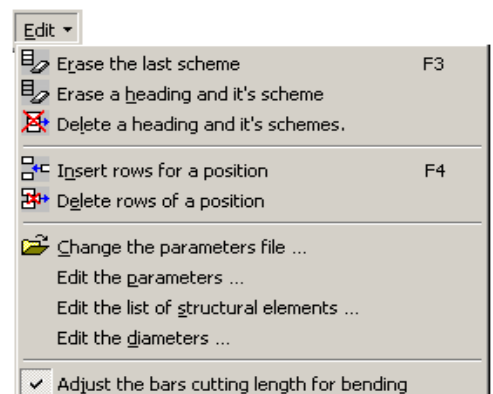

5.2.3 Delete a heading and it's schemes

This is equivalent to the previous command except that the blank space where the heading and it's schemes were represented, disappears.

5.2.4 Insert rows for a position

Inserts one space to introduce a heading or a scheme over the scheme indicated by the active cell, located on the upper left corner.

5.2.5 Delete rows of a position

This is equivalent to the previous command except that a blank space disappears.

5.2.6 Change the parameters file

Opens a parameter file selection box with extension m1x to select the parameters which are chosen to be applied to the current reinforcing bar schedule.

This menu is enabled upon entering **Moebius Soft**, immediately after opening a bar schedule and when requesting a new bar schedule.

5.2.7 Edit the parameters ...

The user gains access to the reinforcing bar schedule parameters edition sheet.

This menu is enabled upon entering **Moebius Soft**, and requesting a new bar schedule.

[See: 4.1 General Parameters]

5.2.8 Edit the list of structural elements ...

The user gains access to the edition sheet for the structural elements which will be used in the

quantities and the steel/concrete ratios. This menu is enabled upon entering Moebius and requesting a new bar schedule. [See: 4.2 Structural elements]

5.2.9 Edit the diameters ...

The user gains access to the bar diameter edition sheet.

[See: 4.3 Bar diameters]

5.2.10 Adjust the bars cutting length for bending

To enable and disenable this option press the mouse's left button while being on the menu

Edit \ Adjust the bars cutting length for bending .

A checkmark to the left of the corresponding menu shows if the option is enabled.

When this option is enabled, all the cutting lengths are adjusted according to the scheme which appears on the "Reference" sheet. The cutting length will be the sum of the partial lengths minus the adjustment for bending.

If it is disenabled the length will be just the sum of the partial lengths.

5.3 View

5.3.1 Normal

Is enabled only when it is in the 'Page Break' mode to which access was gained from the menu.

File \ Preview and it is used to view the "Job Form" in the normal form.

5.3.2 Minimize window

With this command the window is minimized to gain access to the Windows desktop.

5.3.3 Zoom (+)

Enables the Zoom function and approaches the "Job Form" which allows viewing of the schemes in greater detail.

5.3.4 Zoom (--)

Produces the reverse effect compared to the previous command.

5.3.5 Page breaks

Allows viewing of the page breaks while being within the "Job Form".

If the option is enabled a checkmark will appear to the left of the applicable menu.

5.3.6 Reinforcement in cm2, cm2/m

The reinforcing bars are viewed in bleu characters in either cm2 or cm2/m, for the user's information.

The view can be disenabled before printing the "Job Form".

If the option is enabled a checkmark will appear to the left of the applicable menu.

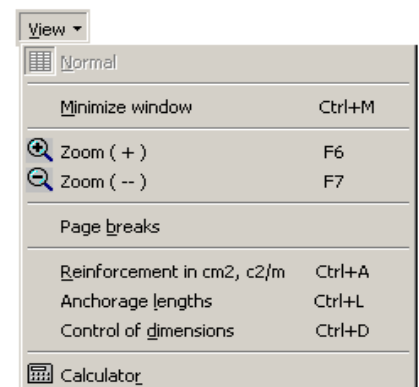

5.3.7 Anchorage lengths

The anchorage lengths are viewed in blue characters. Two values are displayed **la**: anchorage length to the left and **lb**: anchorage length to the right. Both values are calculated based on the basic anchorage length, modified by the applicable factors. [See: 4.3 Bar anchorage]

Moebius Soft calculates the bar extensions which project, for instance, to another beam or slab section as the sum of the distance that's specified in the general parameters plus the anchorage length.

If the option is enabled a checkmark will appear to the left of the applicable menu.

5.3.8 Control of Dimensions

Moebius Soft performs a control of dimensions so that the relationship of the sides of the slabs which are represented in the heading will match the dimensions introduced by the user.

Another dimension control which is performed is that of the maximum and minimum column dimensions. The characters of the control's legend are red.

Viewing of the dimensions control can be disenabled.

5.3.9 Calculator

A calculator is opened. It is recommended to close the calculator when not in use.

5.4 Go

5.4.1 Go to start

Goes to the Job Form's initial cell which is the upper left cell of the first heading and activates it.

5.4.2 Go to end

Goes to the upper left cell of the next space to the last scheme of the "Job Form" and activates it.

5.4.3 Go to position N° ...

To go to a given location in the "Job Form".

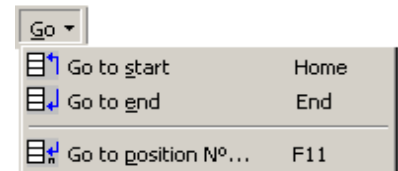

The principal menu commands for the selection of structural types open heading selection sheet or schemes belonging to the requested structural type. The user must activate the upper left cell with a blank space following a heading or scheme before executing some command which requests a structural type.

If one is in a reinforcing bar "Job Form" editing process, **Moebius Soft** will present the selection sheet which matches the previous heading or reinforcing bar scheme.

For example: If the previous reinforcing bar scheme belongs to a longitudinal reinforcing bar scheme of a column and the definition of all the bars which show in the heading has been completed, Moebius Soft will present the stirrup distribution scheme selection sheet.

If the user requests a structural type which does not match the heading or the previous sheet, a message will appear alerting to this situation.

For example: If the user executes the Rectangular slabs command and the active cell is following a column heading, **Moebius Soft** sends a message saying it is not possible to introduce a heading or a reinforcing bar scheme following a slab heading.

First the user must introduce at least one slab reinforcing bar scheme.

Following this reference is made to all the commands which request structural types. The previous explanation also applies to these.

5.5 Slabs

5.5.1 General

5.5.2 Rectangular

5.5.3 Cantilever to the left

5.5.4 Cantilever to the right

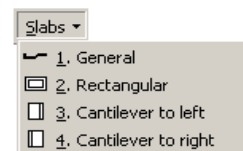

5.6 Beams

5.6.1 Left end span

5.6.2 Middle end span

5.6.3 Right end span

5.6.4 Single span

5.6.5 Cantilever to the left

5.6.6 Cantilever to the right

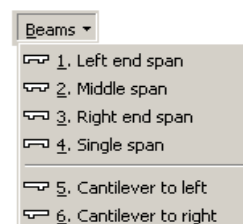

5.7 Supports

- 5.7.1 Square columns
- 5.7.2 Rectangular columns
- 5.7.3 Rectangular columns
- 5.7.4 Circular columns
- 5.7.5 Walls

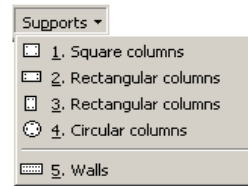

5.8 Foundations

- 5.8.1 Square columns supported on single bases
- 5.8.2 Rectangular columns supported on single bases
- 5.8.3 Rectangular columns supported on single bases
- 5.8.4 Single bases

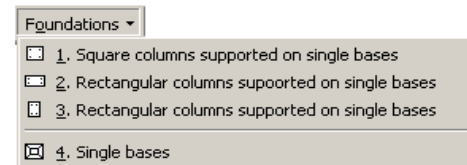

5.9 Help

5.9.1 Moebius Soft help

Pressing F1 shows the manual
 The subject corresponding to the position at the time help is requested will be activated.
 Pressing the mouse's left button while on the words enhanced in blue will show you to the related subjects, you return with the blue arrow.

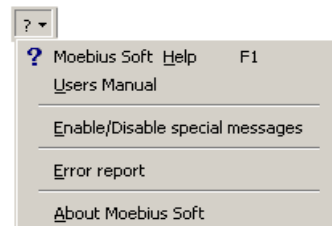

5.9.2 Users manual

The manual can be opened either to view it or to print it.
 Clicking on the small blue circles the user can move to the sub-chapters.

5.9.3 Enable/Disable special messages

A dialog box is opened to individually enable or disable special messages.

5.9.4 Error report

Generate an error report.

5.9.5 About Moebius Soft

Opens a box with the serial N° and general comments about *Moebius Soft*

5.10 Undo last action

With this command the user can undo the last numerical entries to a cell when bar schedule is being edited.
 The command doesn't undo the introduction of a heading or a reinforcing bar scheme.
 In this case the user must erase the heading or schema and re-introduce it.



5.11 Redo last action

This is complementary to the previous command.

5.12 CONTINUE / GO TO THE BAR SCHEDULE

This command is used to continue with the insertion of schemes which belong to the same structural type. To change the structural type the user must select another one from the main menu. Once within the structural module, the menu turns into **GO TO THE BAR SCHEDULE** with which one can return to the Job Form before performing the heading or the corresponding scheme entries.

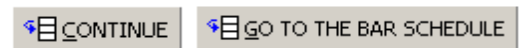

6. Keyboard

In this section we will describe assigning of keys to different commands depending on whether the user is in a "Job Form" sheet or in a heading or scheme selection sheet, in the parameter sheet or in the help.

Abbreviations: Mouse's left button as MLB. Mouse's right button as MRB

6.1 In a reinforcing bar schedule

6.1.1 In the "Job Form" sheet

<u>Key</u>	<u>Command</u>
F1	Activates the Moebius Soft help system
F2	Activates the data edition in a cell.
F3	Erases the last heading or scheme
F4	Inserts a blank space
F6	Approach
F7	Move away
F11	Go to position N°
<i>MLB</i>	If you click it twice it activates editing of a cell
<i>MRB</i>	A menu with several commands appears.
Ctrl + N	Opens a new reinforcing bar "Job Form"
Ctrl + O	Opens a reinforcing bar Job Form
Ctrl + S	Saves a reinforcing bar Job Form
Ctrl + P	Opens a Print dialog box
Ctrl + M	Minimizes the Job Form window
Ctrl + A	Activates viewing of the reinforcing bar area
Ctrl + L	Activates viewing of the anchorage lengths
Ctrl + D	Activates the dimension control
Home / End	Goes to the Job Form's initial / final cell
PageUp / PageDown	Goes to the previous / next scheme
Ctrl + PageUp	Goes to the next previous heading
Ctrl + PageDown	Goes to the next following heading

6.1.2 In the remaining sheets

All keys are disabled except:

- F1 Activates the Moebius Soft help system
- F2 Activates the data edition in a cell. Equivalent to double clicking the MLB

6.2 In the scheme selection sheets

All keys are disabled except:

- F1 Activates the Moebius Soft help system
- F2 Activates the data edition in a cell. Equivalent to double clicking the MLB

6.3 In the parameter, structural elements and diameter sheets

All keys are disabled except:

- F1 Activates the Moebius Soft help system
 - F2 Activates the data edition in a cell. Equivalent to double clicking the MLB
- The PageUp and PageDown keys are enabled

6.4 In the Moebius Soft help sheets

All keys are disabled except for the page displacement ones

A. Installation and system requirements

1. Installing and uninstalling

To install Moebius Soft

For the installation of Moebius Soft Administrator rights are necessary.

Insert the **Moebius Soft** CD in the CD drive. The installation starts automatically. If this does not occur go to *Start \ Run* and select the letter corresponding to the CD drive, next select Setup.exe and press OK. Follow the steps suggested by the installation program.

Put the protection key in you PC's parallel port/USB. You may now connect your printer in the protection key (parallel port) on the side where the caption Printer is.

To uninstall Moebius Soft

With the Windows Start button: select: *Setup \ Control Panel*

Select the icon add or remove programs

Select from the list Moebius Soft and press Add or Remove.

Follow the uninstall program steps.

2. System requirements

Hardware

PC Pentium 350Mhz (minimum) Pentium III 1Ghz (recommended minimum)

128 Mb RAM (minimum) depending on the operating system

256 Mb (recommended)

150MB Hard disk free space (minimum)

CD drive for installation only

Screen resolution: 800x600 (minimum)

Mouse

Printer

Software

Windows 98SE, Me, 2000, XP

Microsoft Excel 2000, XP, 2003

Note :Windows and Excel are registered marks of Microsoft Corporation

B. Sequence to generate a reinforcing bar schedule using Moebius Soft

The recommended steps to generate a reinforcing bar schedule with **Moebius Soft** are the following:
If you are entering for the first time after installation, follow steps 1 to 5. In general follow steps 2 to 5.

Note: you may only enter data in the cells with the red mark in the upper right corner.

1. Edit the parameters, the diameter listing of bars and the items.

► With the menu: *Edition \ Edit the parameters* you gain access to a listing with all of the general data which will be used in the reinforcing bar schedules.

Complete the "Title page" and the "Job Form" data.

The "Title page" data will be reflected in the title pages of all of the bar schedule which are generated.

The data from the bar schedule will be reproduced in each heading and footer of each bar schedule after executing the menu: *File \ Page Setup \ Execute the page setup*

► Edit the materials: the stresses and the description.

Upon selecting the standard several data in the parameter sheet are updated.

To identify these data, place the mouse cursor over the cell with the data. The background color of the label describing the modified data automatically turns deeper.

When selecting ACI as standard, the measurements of the diameters of the sheet are generated in millimeters equivalent to the measurements in inches specified by the ACI.

If the commercial measurements of the diameters of the bars do not match an error message will appear next to each cell with the measurement. You must edit manually these measurements according to the diameter listing to deactivate the error messages thereby making possible exiting from the parameter page.

► With the menu *Parameters \ Save as ...* save the values with a name of your choice.

You can generate several files for different materials and standards for example SIA262_C30/37_B500B, EC2_C30/37_S500 etc. Which later can be opened with: *Parameters \ Change the parameters file* from the parameters or: *File \ Change the parameters file* from the "Job Form".

► With the menu: *Edition \ Edit the diameters* you gain access to a listing of the commercially available diameters, which consists of two columns:

Diameters in mm.: This is the one utilized by **Moebius Soft** for all the calculations. It must be completed with the diameters which will be used to prepare the bar schedules and their measurements in millimeters.

Alternative notation: Is optional. It can be completed, for example, with the diameter measurement in inches.

If the box alternative Notation is activated the description will appear below the diameter's measurement in mm. In each one of the schemes which constitute the "Job Form". You can choose a symbol for the diameter.

► With the menu: *Edition \ Edit the list of structural elements* you gain access to a listing of the elements.

Moebius Soft suggests the first six with which it names the structural elements. If you change these names you must edit the name of the elements in the heading after introducing it in the "Job Form", as there must be a correlation between the names which appear in the "Job Form" and those of the structural elements listing.

2. Change the parameters file

Upon entering **Moebius Soft** a new bar schedule appears. With the menu: *Edition \ Change the parameters file* you may select a parameter's file which will transfer all of the data to the bar schedule.

If you open a bar schedule, and the parameters file used when saving the bar schedule for the last time is different to the current one, a message appears alerting to the situation and suggests the change so as to preserve the consistency of the data.

3. Complete Job Form's general heading

The general heading of the "Job Form" is located at the beginning of the sheet: "Job Form", and it can be distinguished by the double line of it's borders.

Job, Bar schedule, Materials and Date will show up in the heading of each sheet after executing the menu *File \ Page setup \ Execute the page setup*. Plan and Comments are shown in the "Title Page".

4. Execute the menu *File \ Page setup \ Execute the page setup and next save the file*

Note: Previously activate the upper left cell of the frame corresponding to the first heading whose border features bold lines.

With this menu, the heading and footers of each sheet of the reinforcing bar schedule are generated automatically and the following sheets are formatted: "Title page" [A], "References" [B], "Quantities" [C], "Steel/Concrete Ratios" [D] and "Job Form" [E].

► With the menu: *File \ Page setup \ Values for the page setup of this sheet* each one of the sheets can be setup manually and next, Moebius suggests to save the values of the setup which will be valid each time a page setup is executed.

To return to the default values you may execute the menu: *File \ Page setup \ Predefined Values for the page setup*.

► Next save the bar schedule with the menu: *File \ Save* or: *File \ Save as*.

5. Choose a structural type and start generating the reinforcing bar schedule

C. Installing the different versions of Excel in the same computer

1. *Installing a new version of Excel while keeping the previous one.*

Nowadays the Excel installers always ask the user if he wishes to maintain the previous version. Simply, you must install the new version in a different directory from the one where the current version is. Before performing the installation, it is recommended to create a directory with the name of your choice so that the installer can copy the files to that location.

The suggested default directory, by the Office installer is: Program files \ Microsoft Office.

If you have in your computer the 2000 version of Excel and you wish to keep it, generate, for example, the directory: Program files \ Microsoft Office 2003 before installing the new version of Excel and when the installer requests the name for a different directory to proceed with the installation, give him the one you generated to that effect.

2. *Installation of a previous version of Excel*

To install a previous version of Excel:

- a. Uninstall the current version
- b. Generate a directory to house the previous version
- c. Install the previous version in the directory you generated to that effect
- d. Reinstall the newer version

3. *Start with a previous version of Excel*

Click with the Mouse's right button over the **Moebius Soft** shortcut icon

Select "properties" and next the "shortcut" option

In the destination specification substitute:

"C:\.....\Moebius\Program\Moebius.xll" becomes:

C:\Program files\Microsoft Office 2000\Office\EXCEL.EXE /e "C:\.....\Moebius\Program\Moebius.xll"

where: *C:\Program files\Microsoft Office 2000\Office* is the location for the previous version of Excel

Note: The addition of "/e" causes Excel to start while concealing the picture with the corresponding logotype.

D. Anchorages and bending diameters per different codes

D.1 EC2

D.1.1 Anchorage of bars.

Basic length of anchorage: value in number of diameters as a function of concrete the steel.

	Concrete specified stress in MPA							
Steel	16	20	25	30	35	40	45	50
420	46	40	34	30	27	25	23	21
500	54	47	40	36	32	29	27	25

Favorable location factor = **1**

Unfavorable location factor = **1.4**

Thickness of the zone differentiating element = **25 cm**

Reinforcement size reduction factor = **1**

Bar end hook reduction factor = **0.7**

D.1.2 Bending diameters of bars, hooks and stirrups.

Bars:

Option = **For lateral cover**

d1 = **15 φ** for lateral cover > 50 mm / 3 diameters.

d1 = **20 φ** for lateral cover < = 50 mm / 3 diameters.

Hooks

d2 = **4 φ** for bar diameters < 20 mm.

d2 = **7 φ** for bar diameters > = 20 mm.

Stirrups

d3 = **4 φ** for bar diameters < 20 mm.

d3 = **7 φ** for bar diameters > = 20 mm.

D.2 SIA262

D.2.1 Anchorage of bars.

Basic length of anchorage: value in number of diameters as a function of concrete the steel.

	Concrete specified stress in MPA							
Steel	16	20	25	30	35	40	45	50
450	54	47	41	36	33	30	27	26
500	60	52	45	40	36	33	30	29

Favorable location factor = **1**

Unfavorable location factor = **1.4**

Thickness of the zone differentiating element = **25 cm**

Reinforcement size reduction factor = **1**

Bar end hook reduction factor = **0.7**

*EC2

*EC2

D.2.2 Bending diameters of bars, hooks and stirrups.

Bars:

d1 = **15 φ**

Hooks

d2 = **6 φ** for bar diameters < = 20 mm.

d2 = **8 φ** for bar diameters > 20 mm.

Stirrups

d3 = **4 φ** for bar diameters < = 16 mm.

d3 = **7 φ** for bar diameters > 16 mm.

D.3 DIN1045

D.3.1 Anchorage of bars.

Basic anchorage length value in number of diameters as a function of concrete and steel.

	Concrete specified stress in MPA							
Steel	13	17	21	25	30	38	47	
420	43	38	33	30	27	23	20	
500	51	45	40	36	32	27	24	

Favorable location factor = 1

Unfavorable location factor = 2

Thickness of the zone differentiating element = 25 cm

Reinforcement size reduction factor = 1

Bar end hook reduction factor = 0.7

D.3.2 Bending diameters for bars, hooks and stirrups

Bars:

Option = For lateral cover

d1 = 15 ϕ for lateral cover > 50 mm / 3 diameters

d1 = 20 ϕ for lateral cover < = 50 mm / 3 diameters

Hooks

d2 = 4 ϕ for diameters of the bar < 20 mm.

d2 = 7 ϕ for diameters of the bar > = 20 mm.

Stirrups

d3 = 4 ϕ for diameters of the bar < 20 mm.

d3 = 7 ϕ for diameters of the bar > = 20 mm.

D.4 ACI

D.4.1 Anchorage Bar

Basic anchorage length: value in diameters as a function of concrete and steel.

	Concrete specified stress in MPA							
Steel	15	20	25	30	35	40	45	50
420	52	45	40	37	34	32	30	28
500	62	54	48	44	40	38	36	34

Favorable location factor = 1

Unfavorable location factor = 1.3

Thickness of the zone differentiating element = 30 cm

Reinforcement size reduction factor = 0.8 if the reinforcement diameter < = than 20 mm

Bar end hook reduction factor = 0.5

D.4.2 Bending diameters for bars, hooks and stirrups.

Bars:

Option = By reinforcement size

d1 = 6 ϕ for bar diameters < = 25 mm.

d1 = 8 ϕ for bar diameters > 25 mm.

Hooks

d2 = 4 ϕ for bar diameters < = 25 mm.

d2 = 8 ϕ for bar diameters > 25 mm.

Stirrups

d3 = 4 ϕ for bar diameters < = 16 mm.

d3 = 6 ϕ for bar diameters > 16 mm.

Note: The typical stress values for concrete are given in MPA for 15x30cm cylinders.

The typical stress values for steel are given in MPA.

The values of the anchorage length are given for the favorable adherence zone.

E. Default values for the page setup

	Title Page	References	Quantities	St./Con. Ratios	Job Form
Percentage	90%	90%	90%	90%	85%
Upper Margin	2.0 cm	3.0 cm	3.0 cm	3.0 cm	3.0 cm
Lower Margin	2.0 cm	3.0 cm	3.0 cm	3.0 cm	2.5 cm
Left Margin	2.5 cm	2.5 cm	2.5 cm	2.5 cm	2.5 cm
Right Margin	0.5 cm	0.5 cm	0.5 cm	0.5 cm	0.5 cm
Heading	1.3 cm	1.3 cm	1.3 cm	1.3 cm	1.3 cm
Footer	1.3 cm	1.3 cm	1.3 cm	1.3 cm	1.3 cm
Hor.Center.	No	No	No	No	No
Vert.Center.	Yes	No	No	No	No
Orientation	Vertical	Vertical	Vertical	Vertical	Vertical
Paper	A4	A4	A4	A4	A4
Schemes per sheet	-	-	-	-	6